







ISTRUZIONI DI MONTAGGIO
INSTRUCCIONES DE MONTAJE
ASSEMBLY INSTRUCTIONS

 **Max 150 kg**
 **10 - 10,76 mm**
 **12 - 12,76 mm**
 **3500 mm**
 **Min 600 / Max 1200**

 **Illimitate/ Ilimitado**
 **+ 6 / - 3 mm**

Attrezzi richiesti / Herramientas necesarias / Required tool

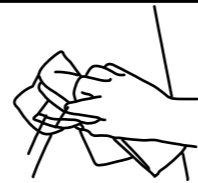
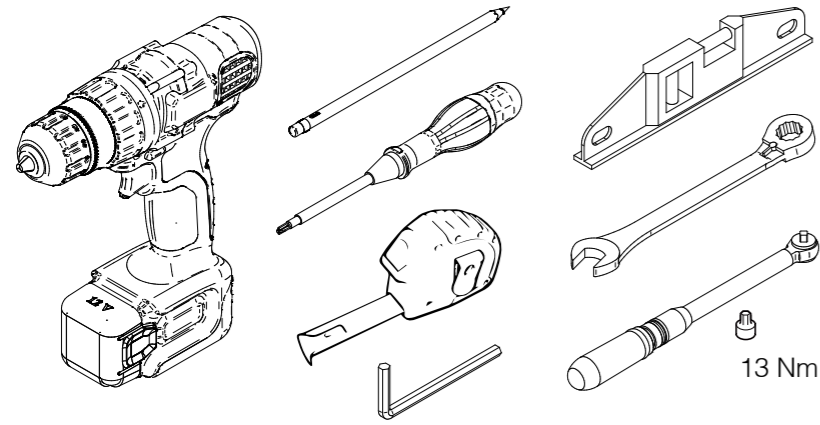

Pulire il vetro ed i profili prima dell'installazione.

Limpiar el cristal y los perfiles antes de la instalación.

Clean the glass and profile before installing.

Componenti - Componentes - Components

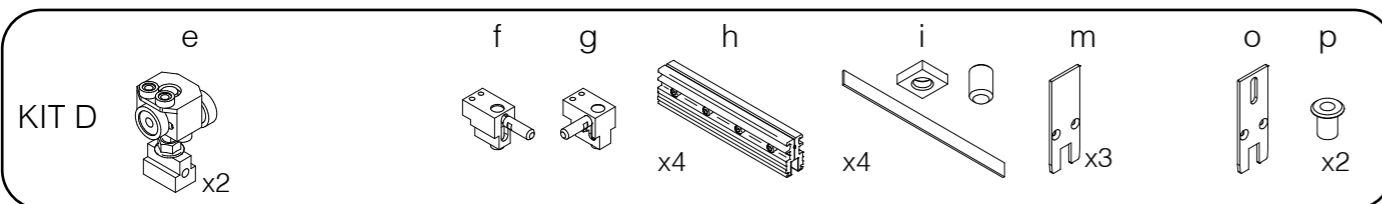
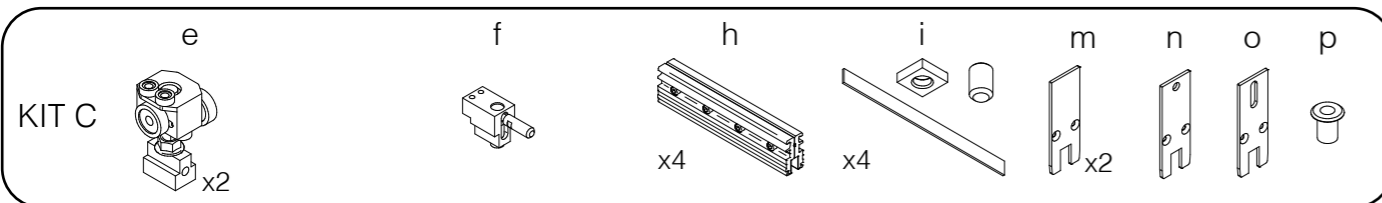
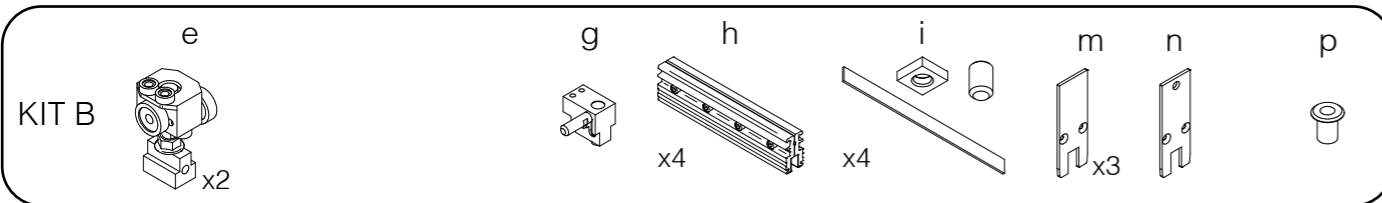
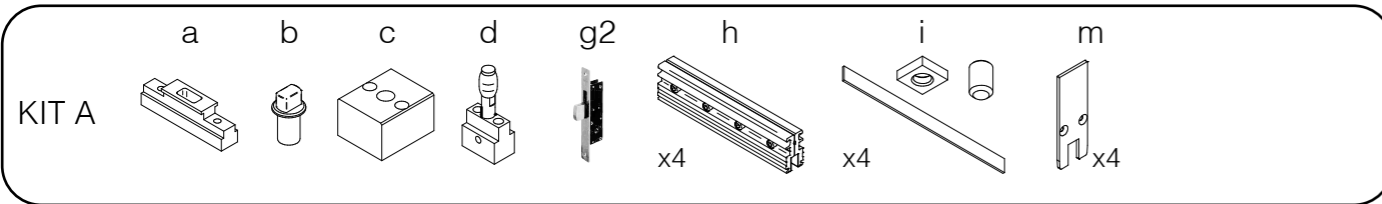

PROFILI - PERFILES - PROFILES

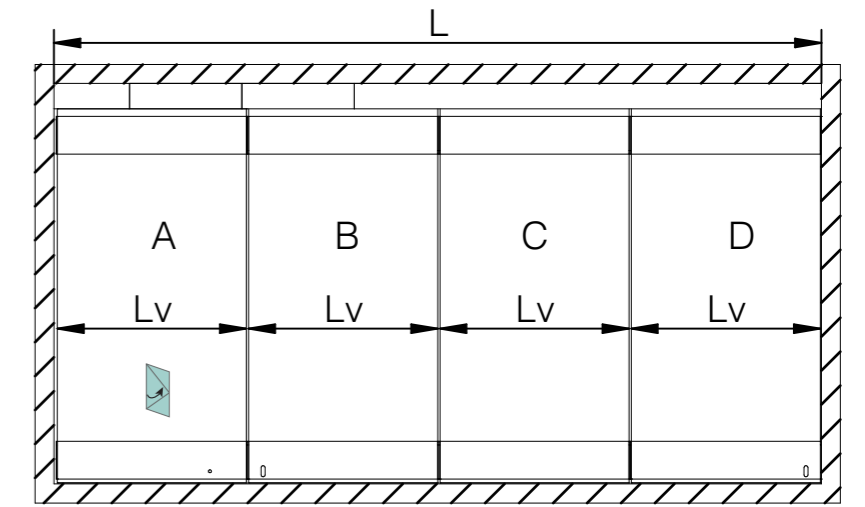
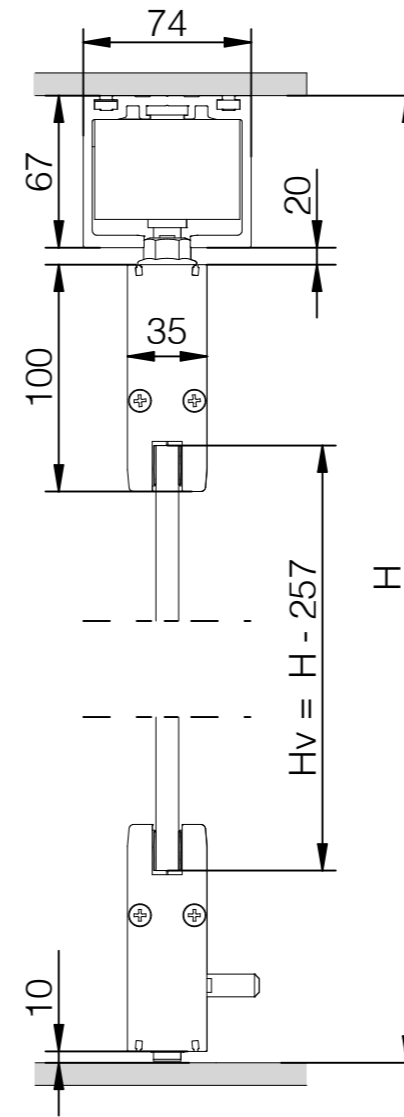
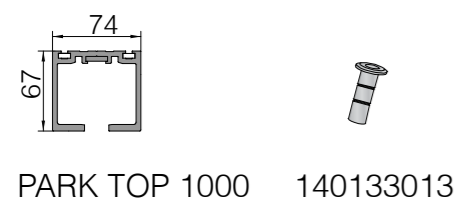

$$H_v = H - 257$$

$$L_v = \frac{L - 6}{N} - 6$$

N = numero di ante
number of panels
numero de hojas

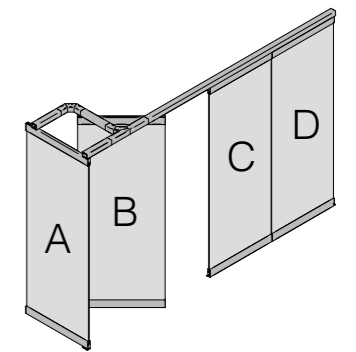

PROFILI - PERFILES - PROFILES

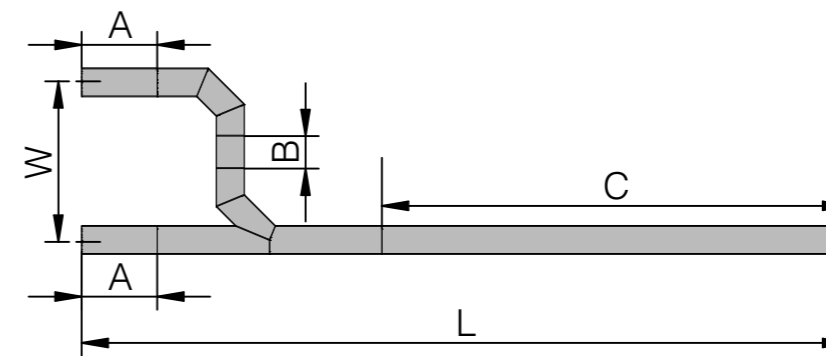

$$A = N \times 70$$

$$W = L_v - 140$$

$$B = W - 417$$

$$C = L - A - 594$$

Machining clamps profile - Mecanización del perfil de pinza

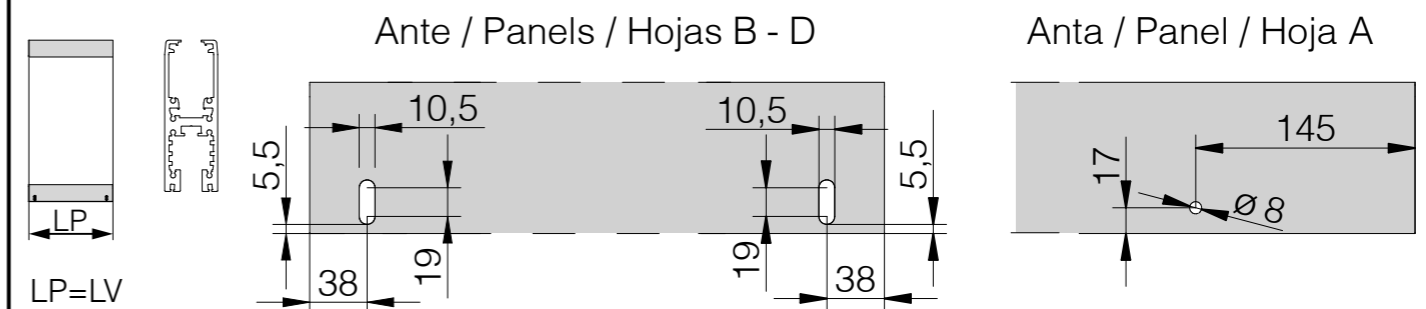

1a Assemblaggio binario - Profile assembly - Montaje perfil corredero
Le giunzioni binario variano a seconda del progetto

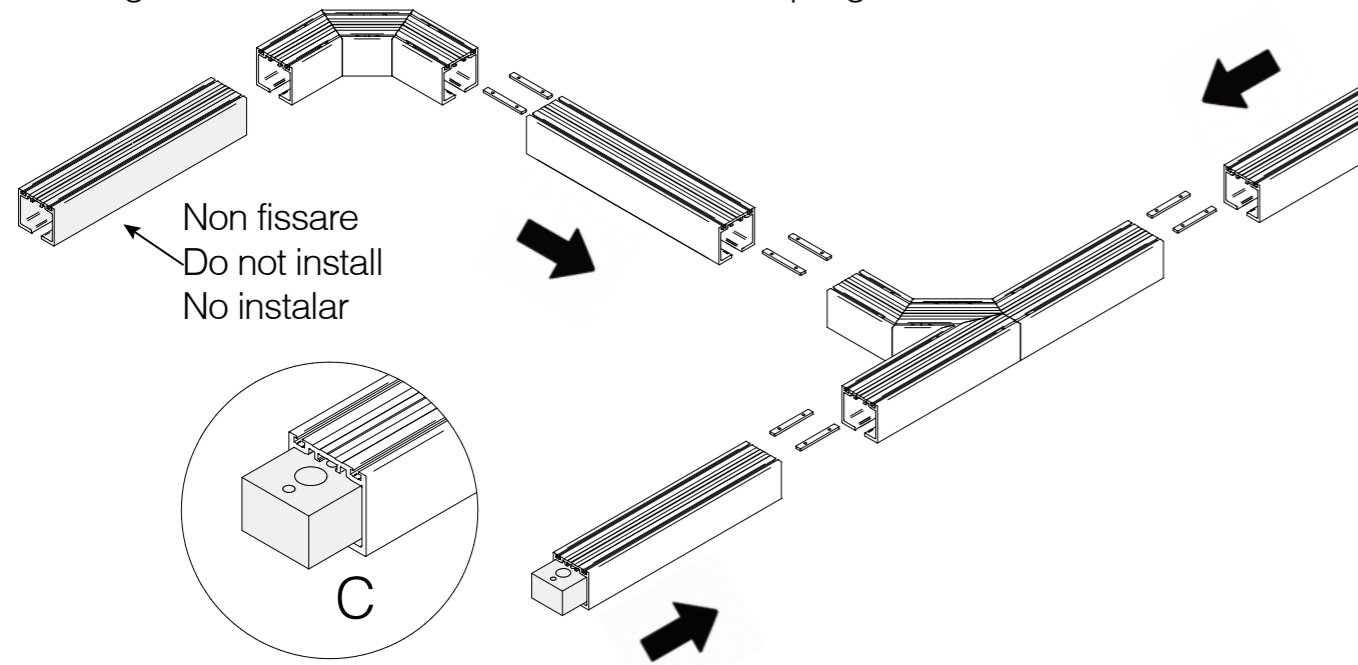

1b Fissaggio binario - Profile fix - Fijar el perfil corredero

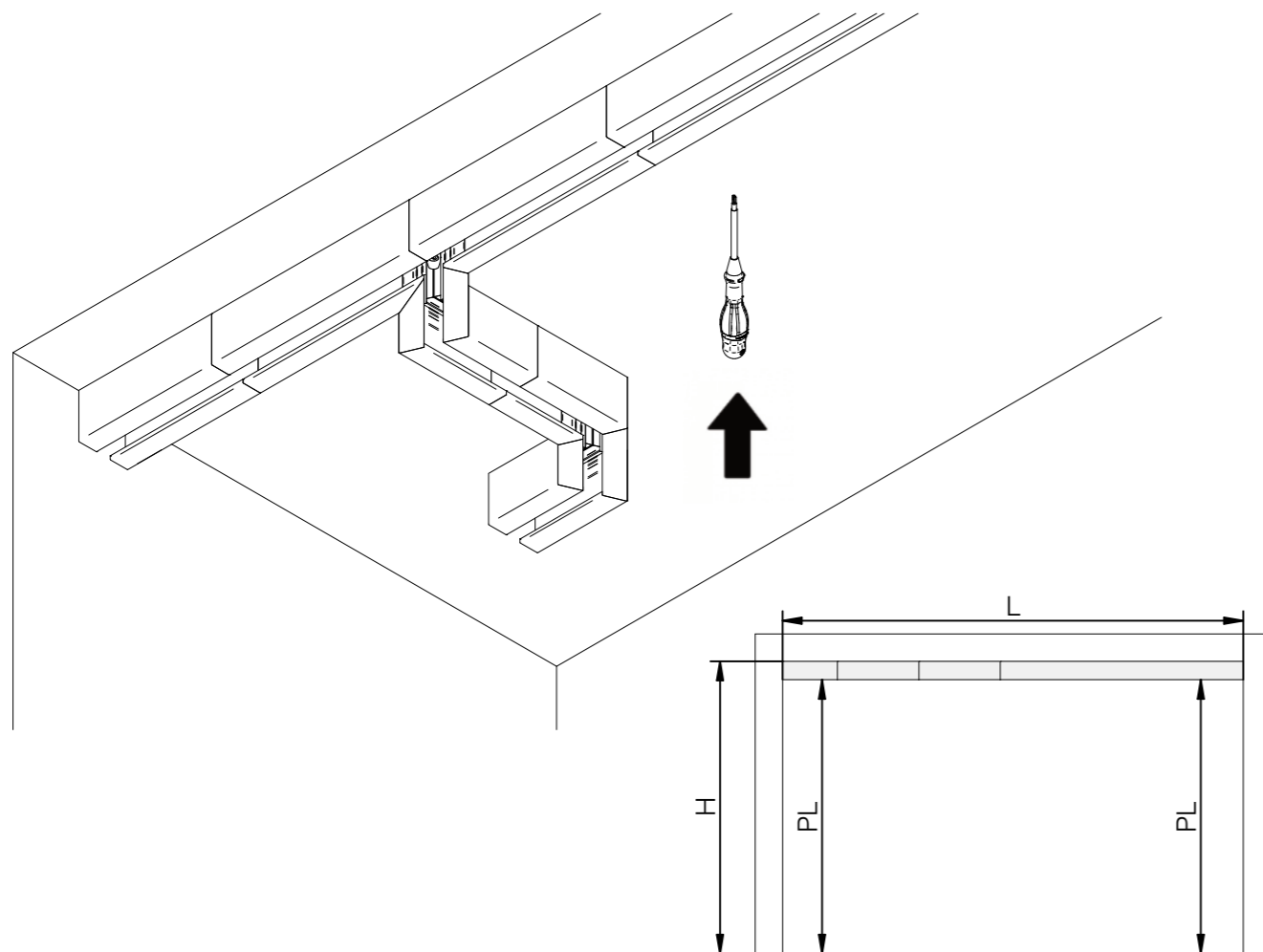

2 Installazione profilo pinza - Assembly clamps profile - Montaje perfil pinza

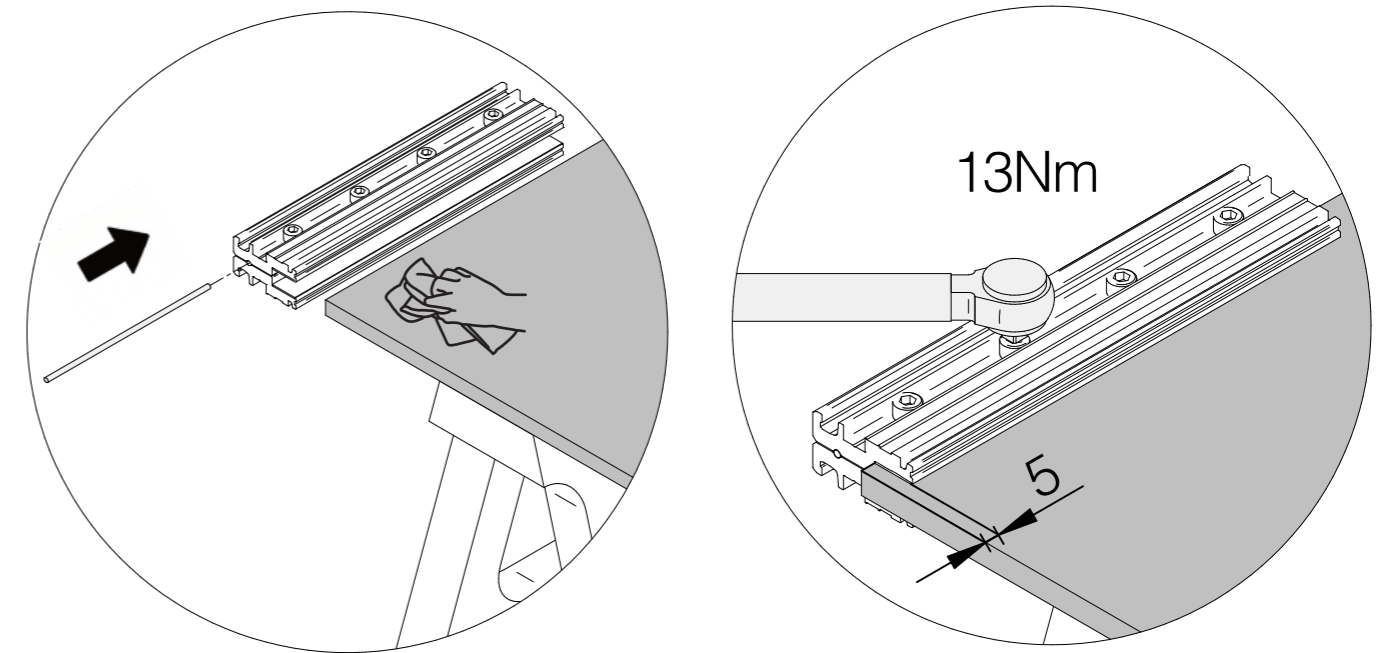

Inserire il distanziatore nella pinza
Insert the spacer in the clamp
Insertar el espaciador en la pinza

Posizionare e serrare la pinza sul vetro pulito
Place and screw the clamp on the clean panel
Colocar y atornillar las pinza en el cristal limpio

Ø 3	10 mm
Ø 3,5	10,76 mm
Ø 4	12 mm
Ø 4,5	12,76 mm

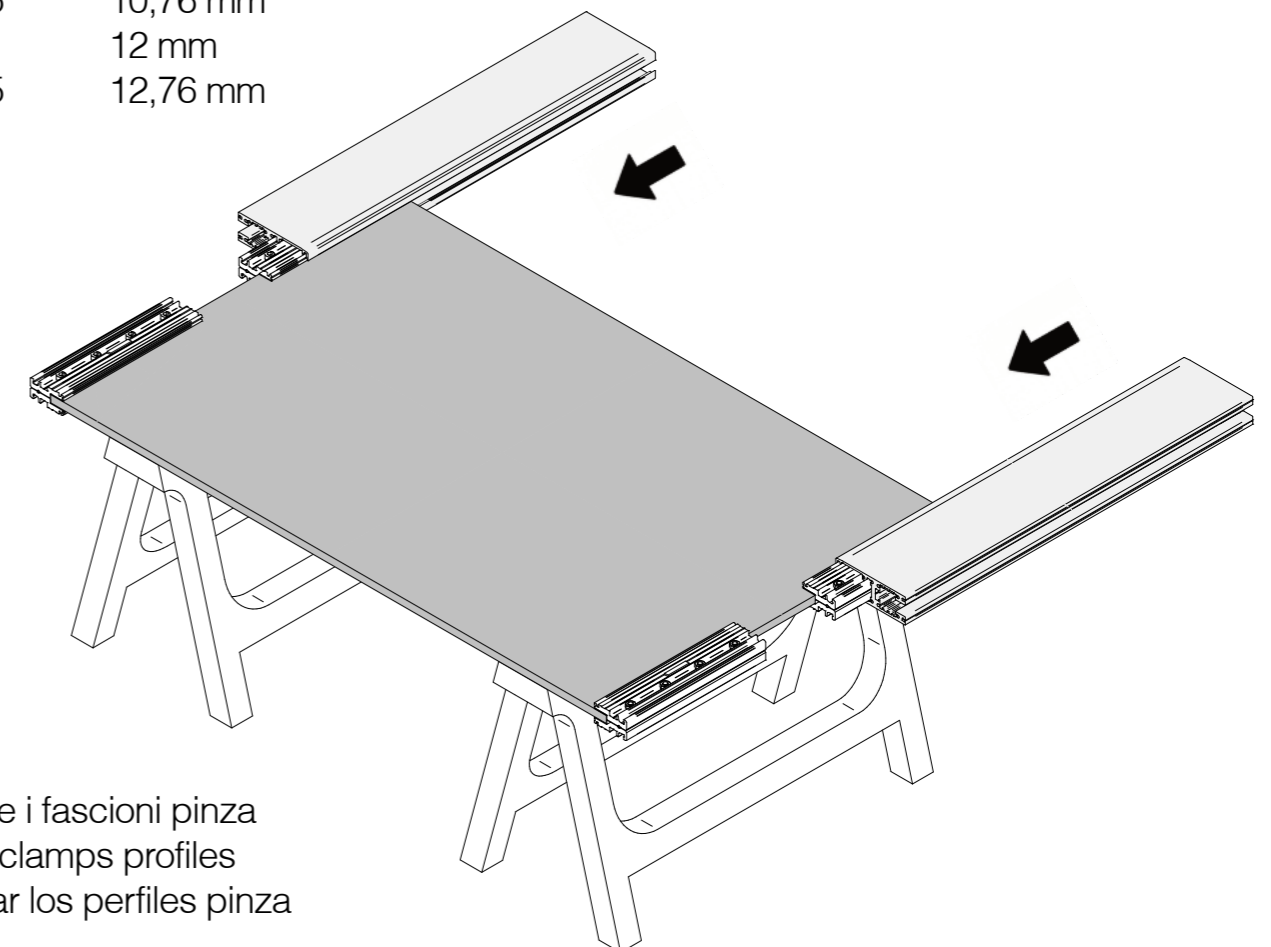

Inserire i fascioni pinza
Insert clamp profiles
Insertar los perfiles pinza

3 Serraggio fascione pinza - Tightening clamp profile - Fijación perfil pinza

Inserire la piastrina nel profilo pinza
 Insert the platelet in the clamp profile
 Insertar la platina en la pinza

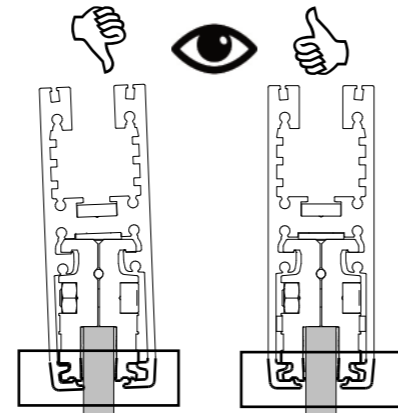
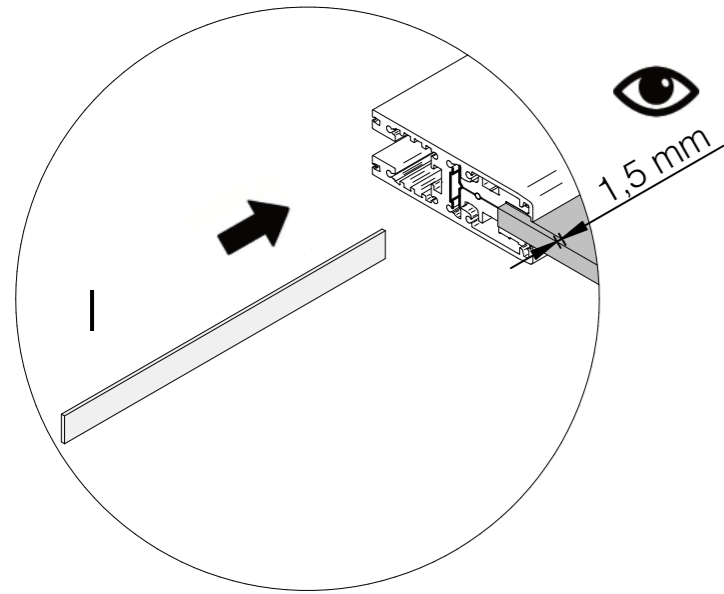

Verificare il corretto posizionamento
 Verify the right position of the clamp
 Verificar el posicionamiento correcto

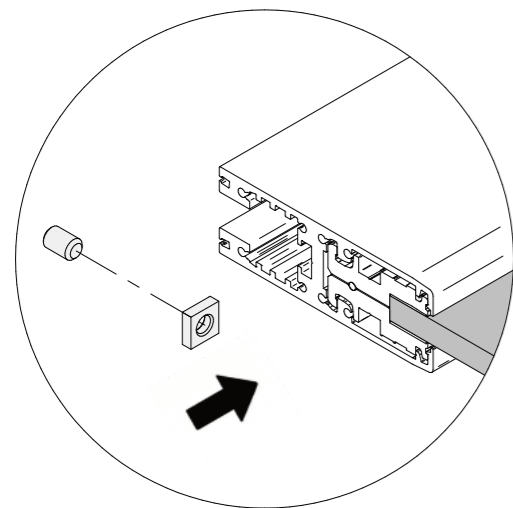
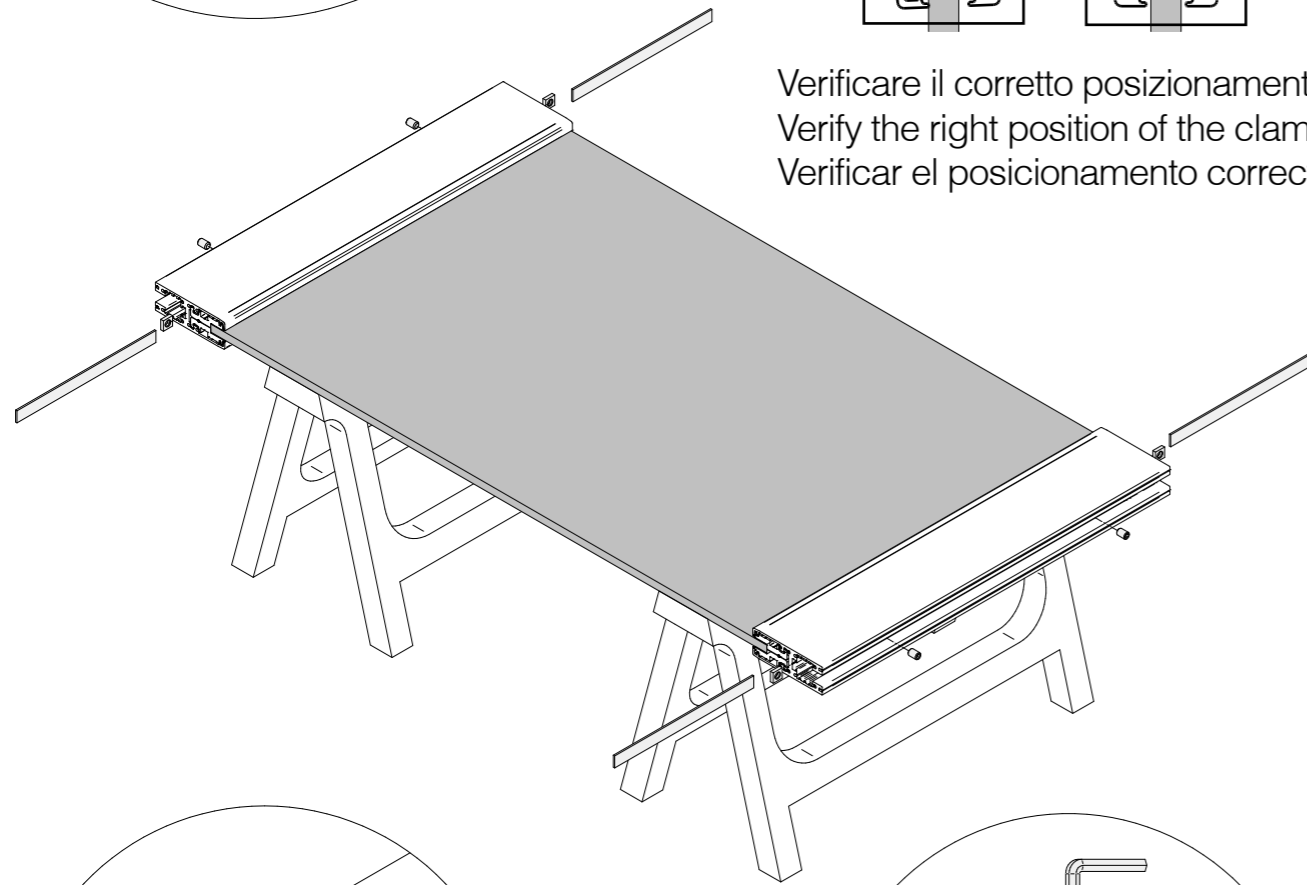

Serrare - Screw - Atornillar

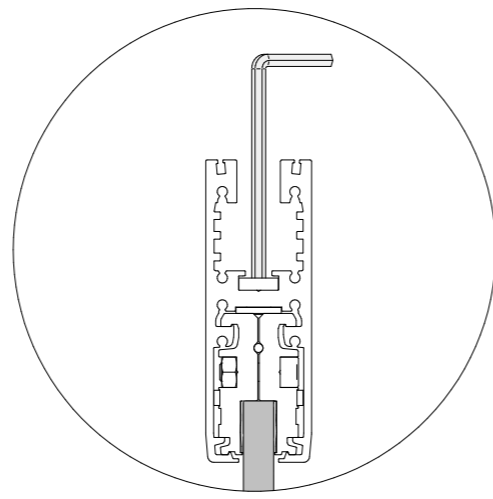

4 Assemblaggio anta "D" - Assembly panel "D" - Montaje hoja "D"

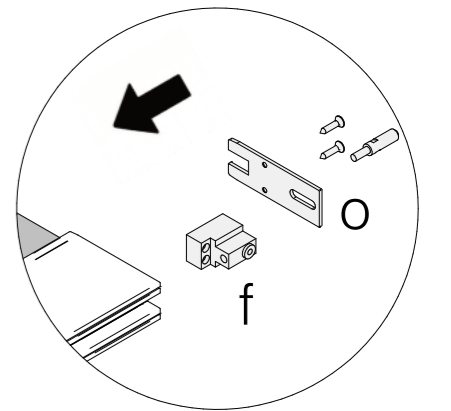
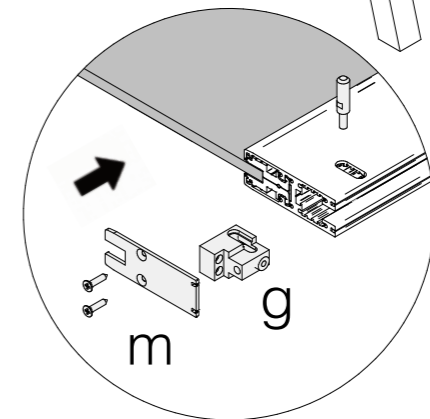
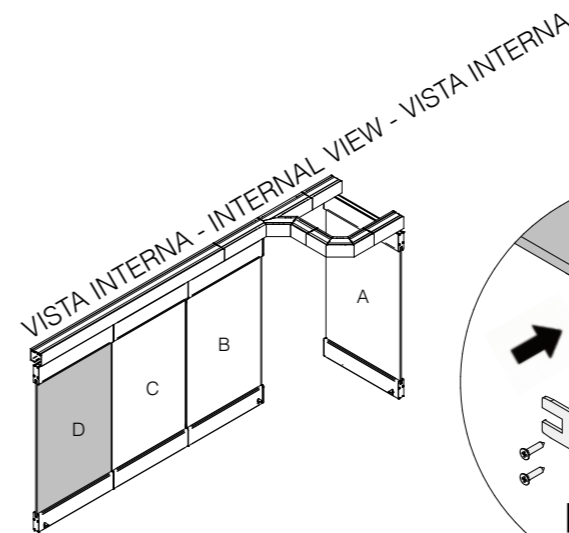
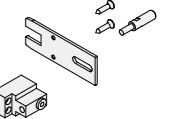
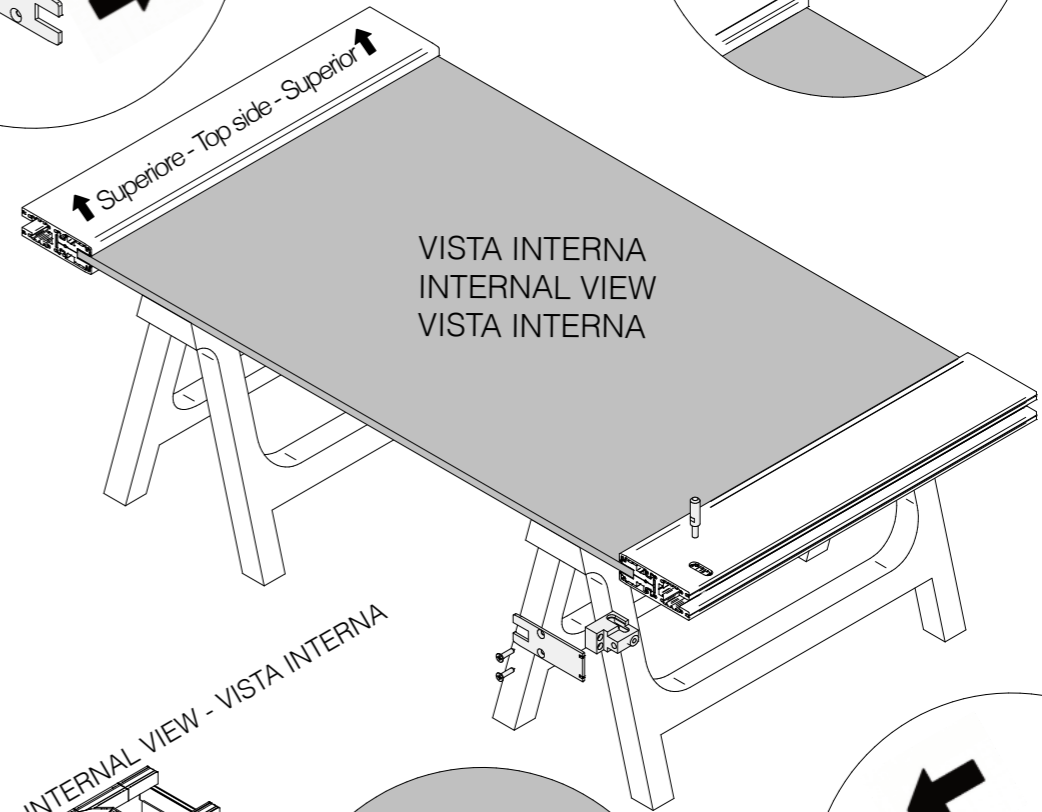
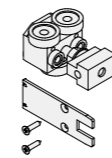
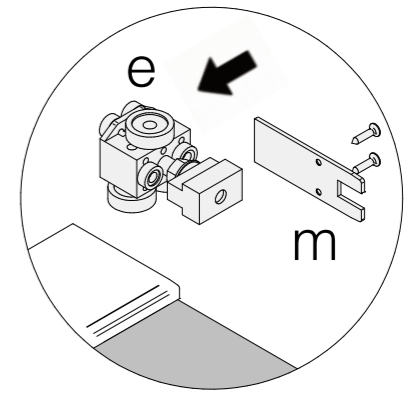
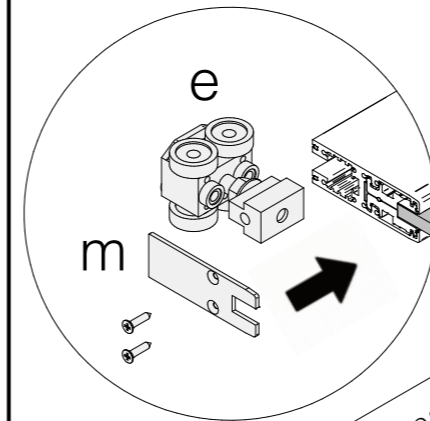
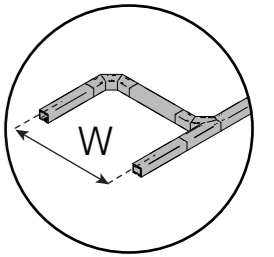
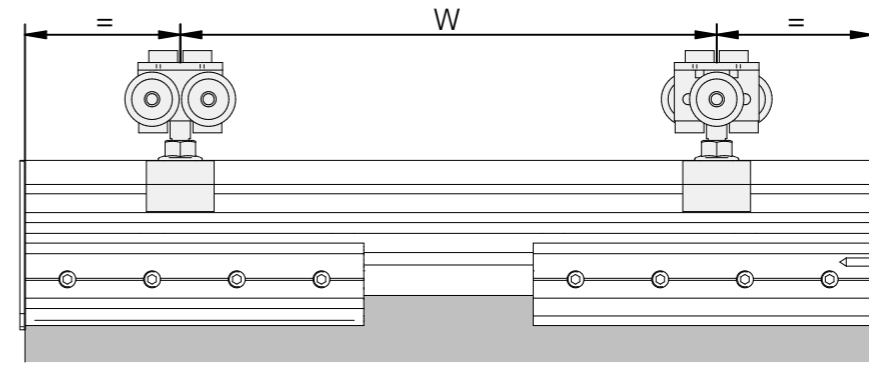

5 Assemblaggio anta "C" - Assembly panel "C" - Montaje hoja "C"

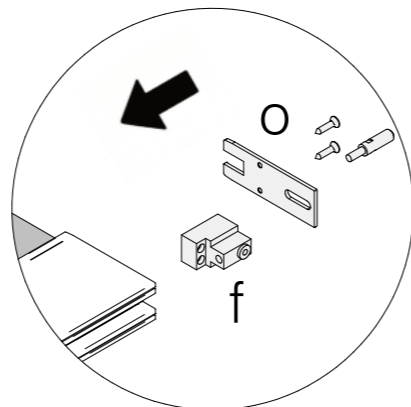
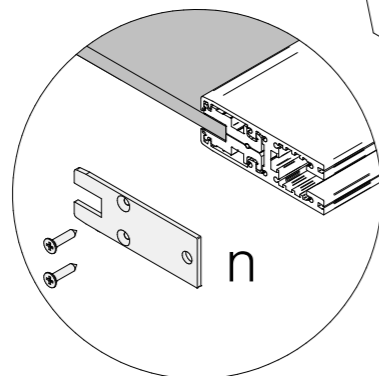
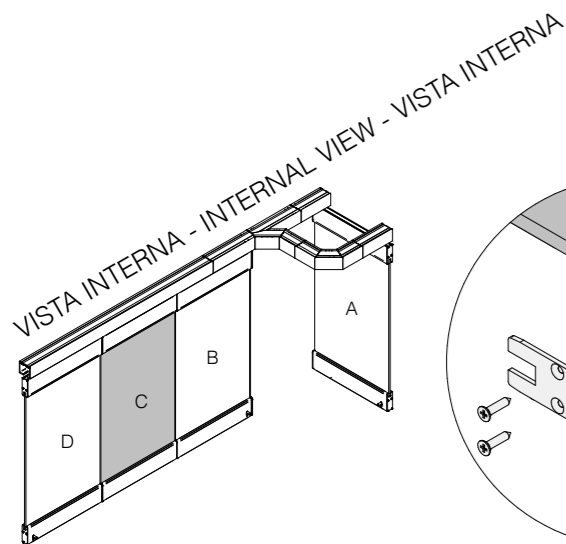
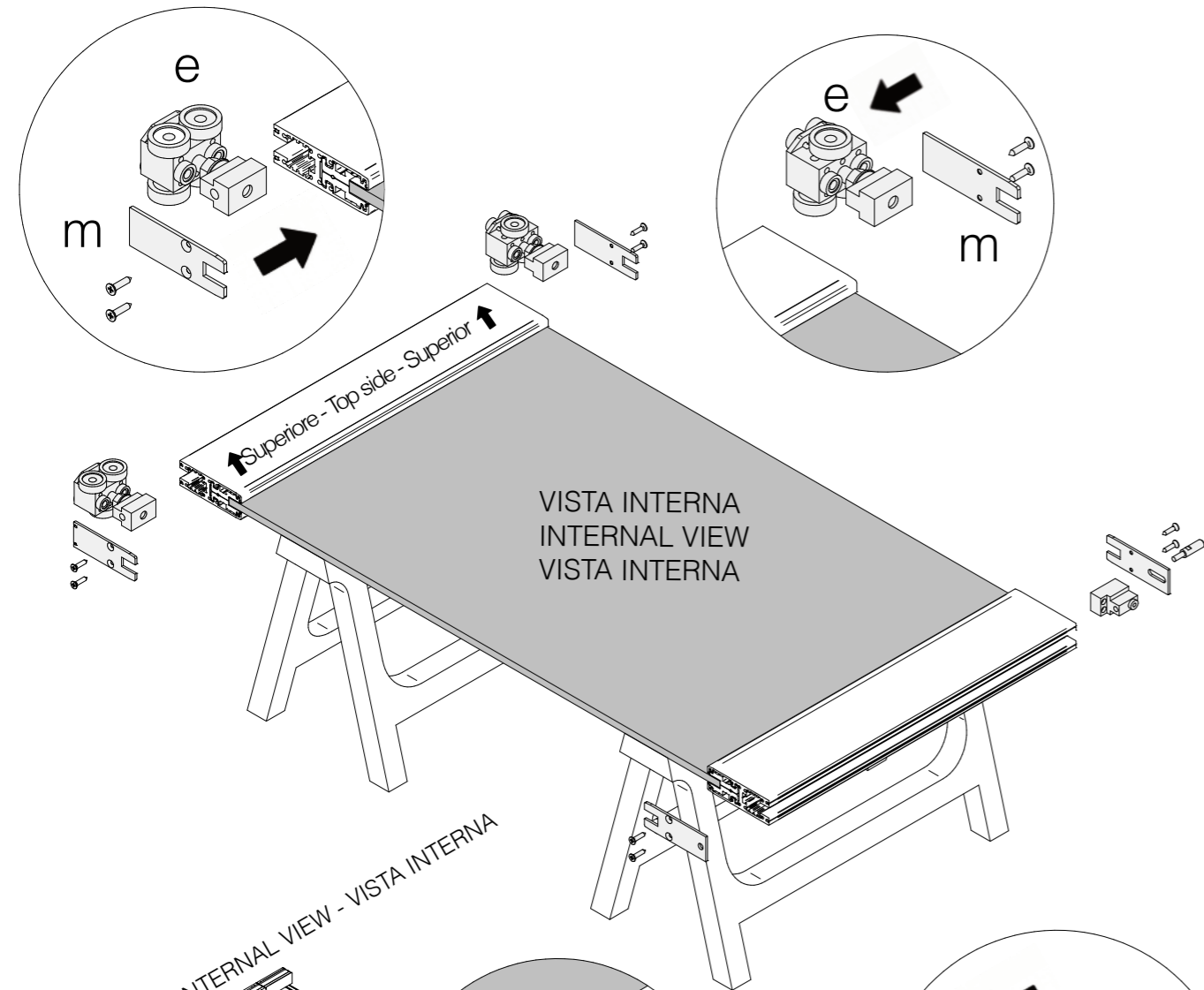
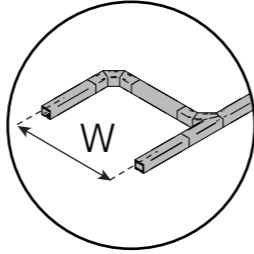
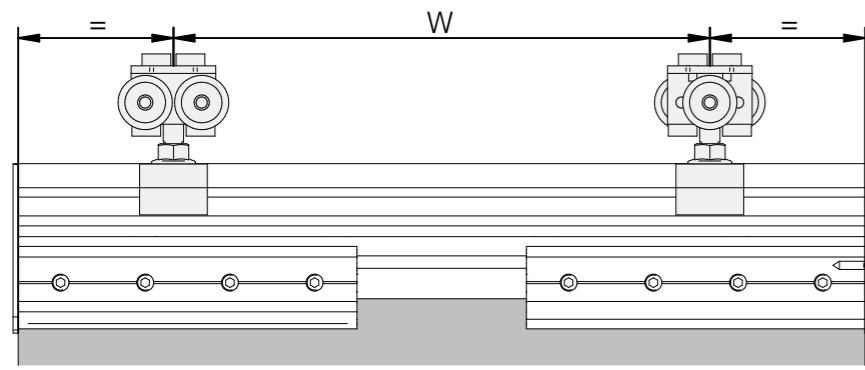

6 Assemblaggio anta "B" - Assembly panel "B" - Montaje hoja "B"

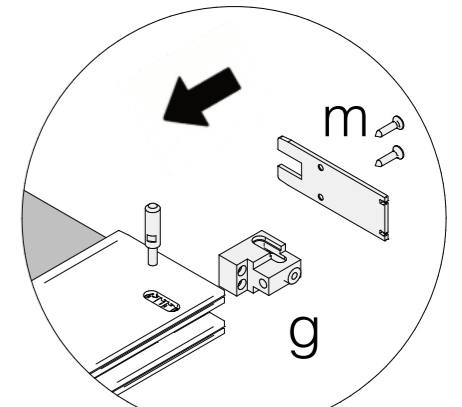
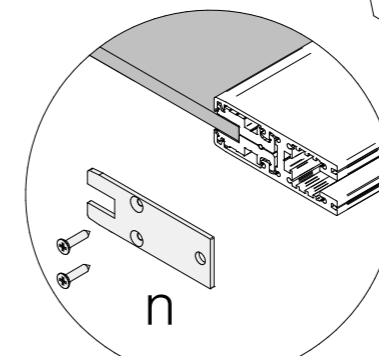
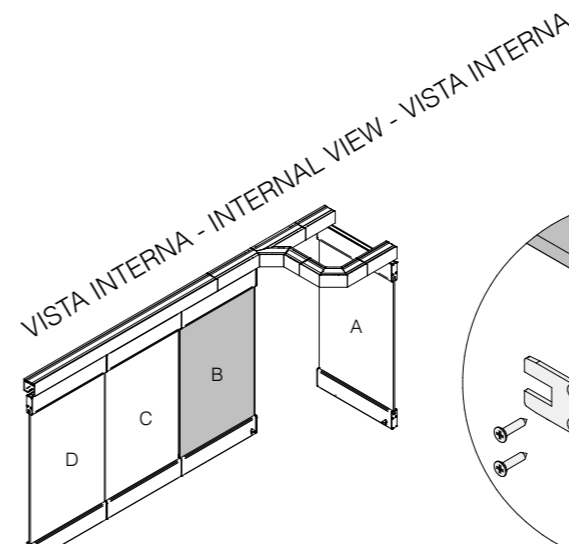
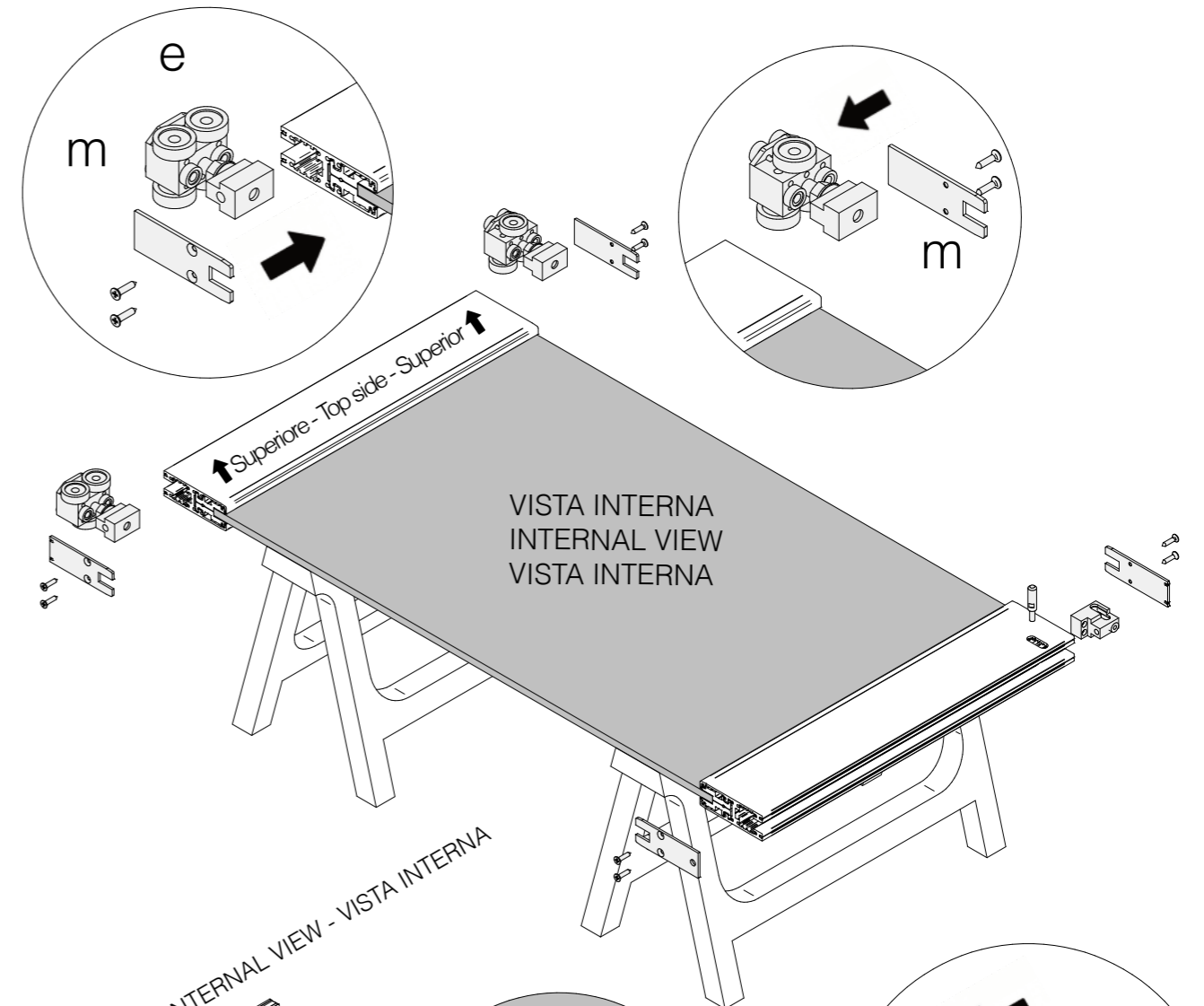
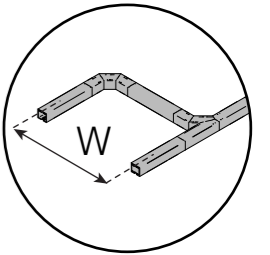
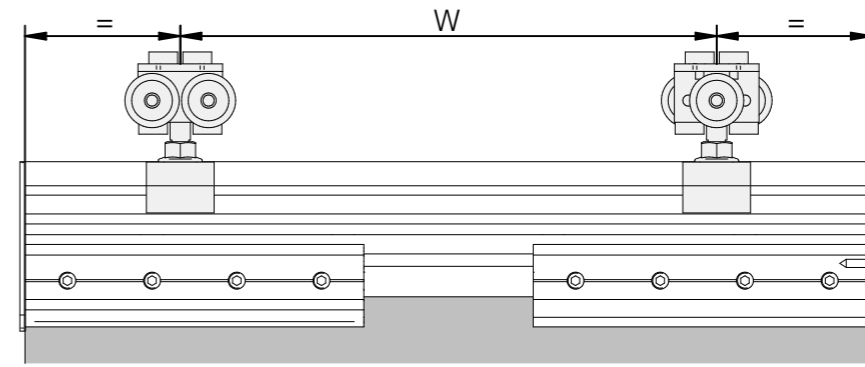

7 Assemblaggio anta "A" - Assembly panel "A" - Montaje hoja "A"

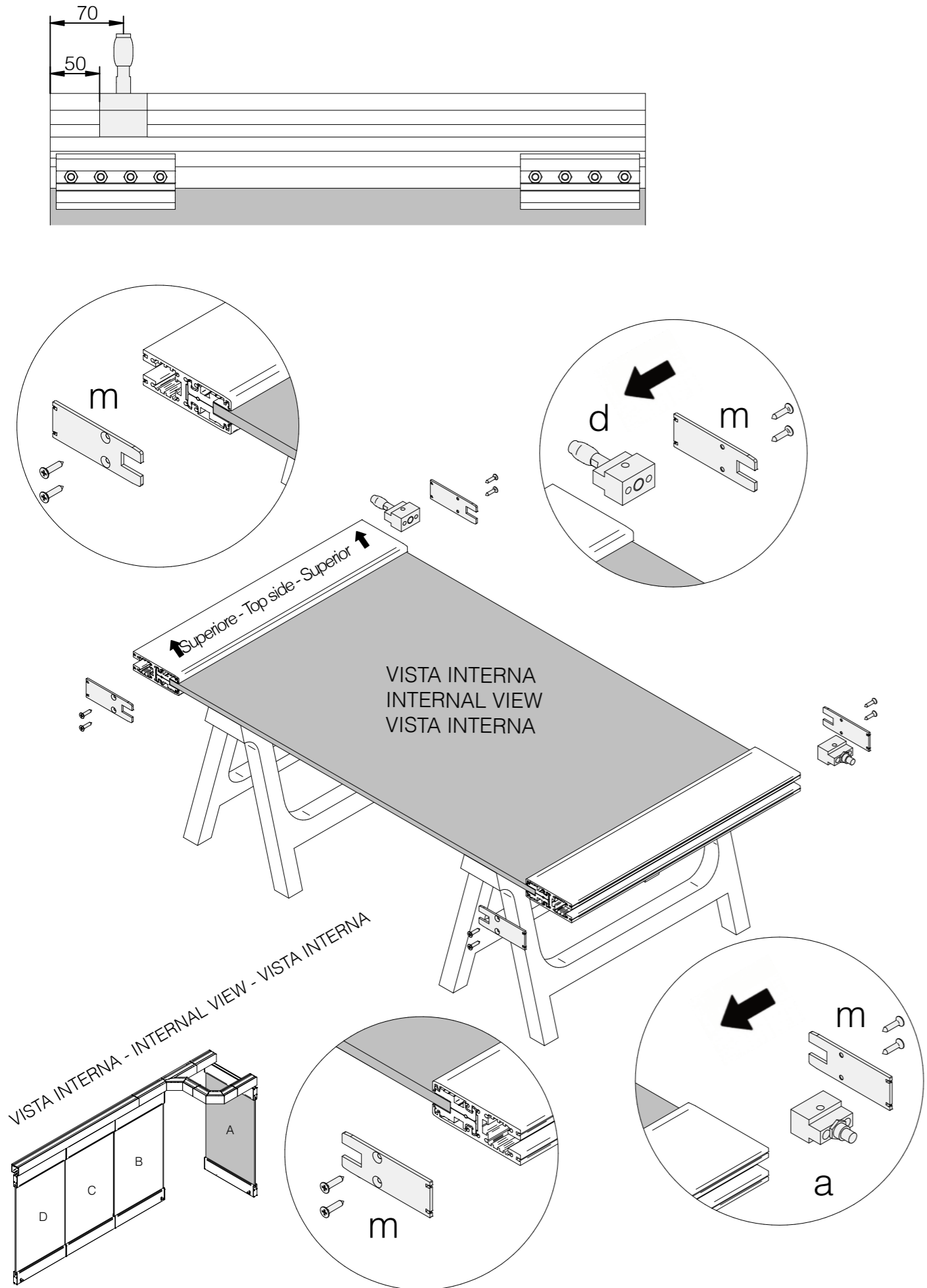

8 Installazione delle ante - Panels mounting - Instalación de hojas

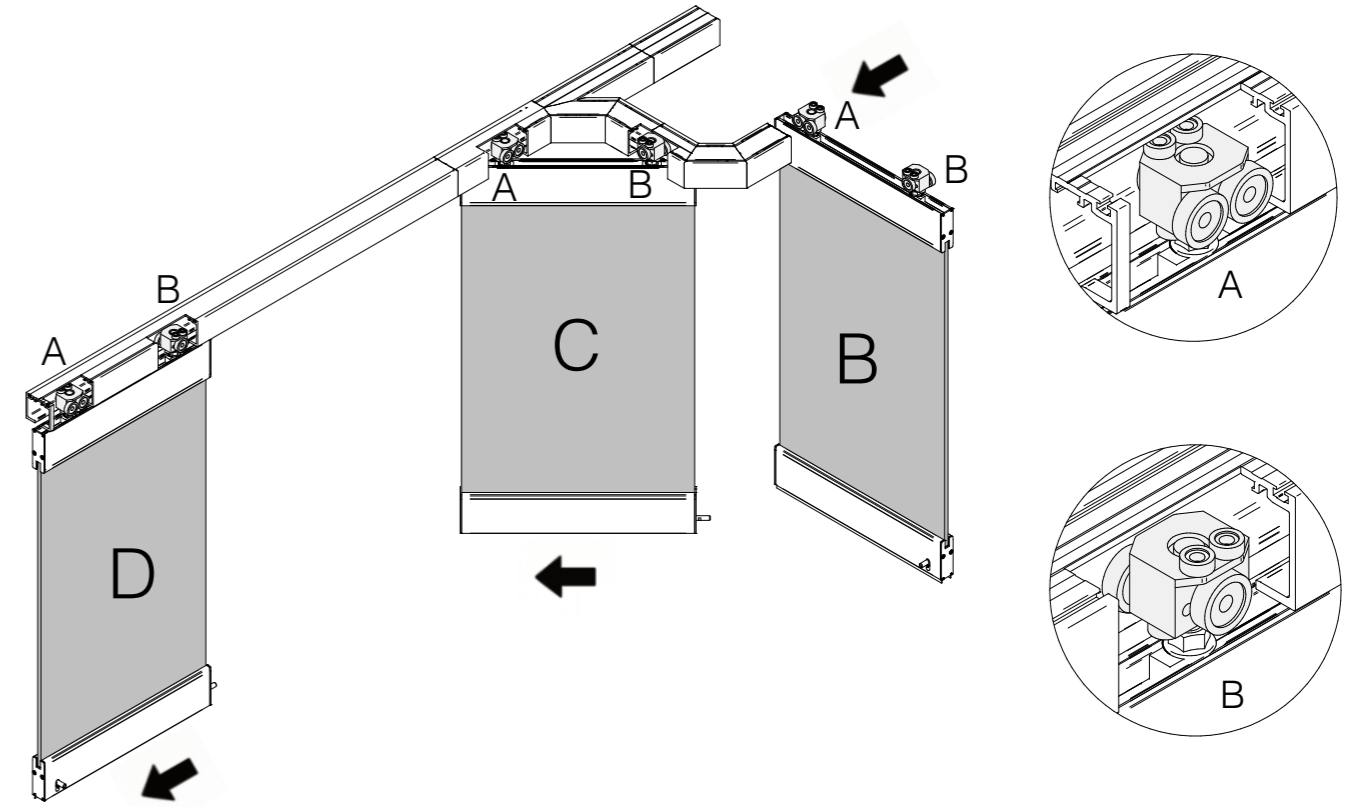

9 Fissaggio sezione binario
Section profile fix
Fijar la sección del perfil corredero

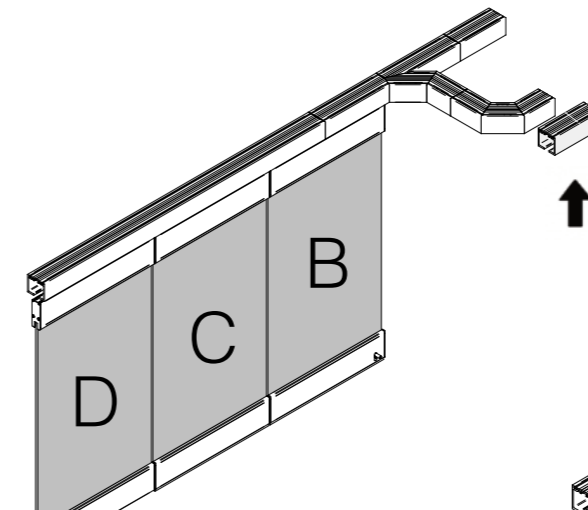

10 Installazione del deviatore
Fix the switch component
Fijar el derivador

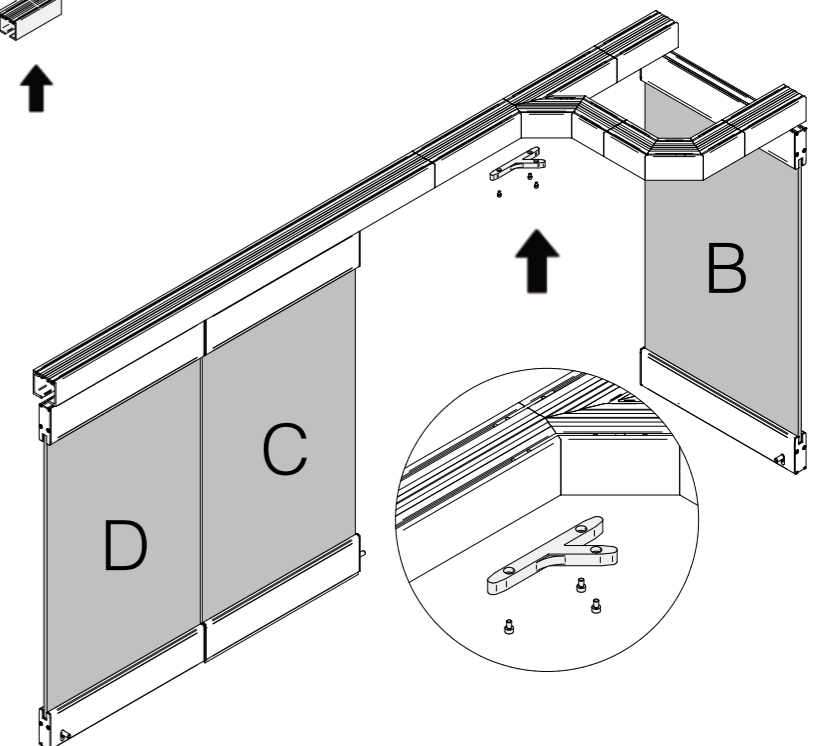

12 Regolare e serrare i carrelli - Adjust and screw the trolley
Regular y serrar las roldanas

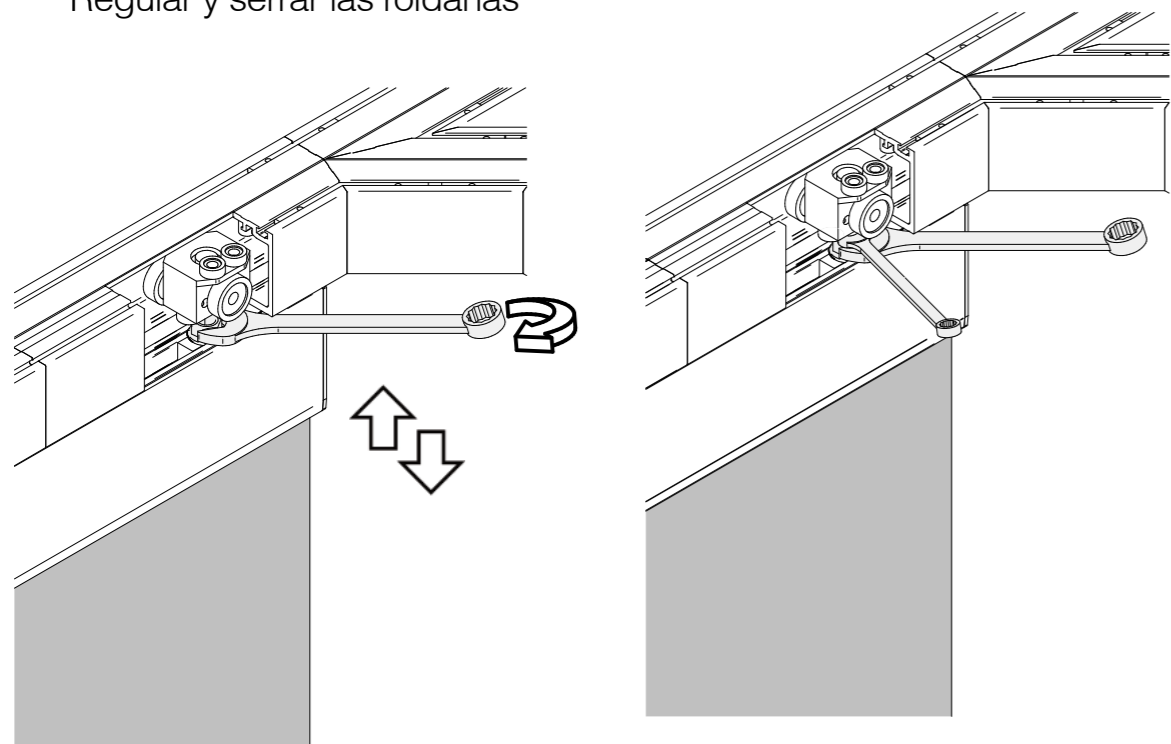

13 Installazione spazzolini e guarnizioni - Assembly brushes and seals - Montaje cepillos y sellos

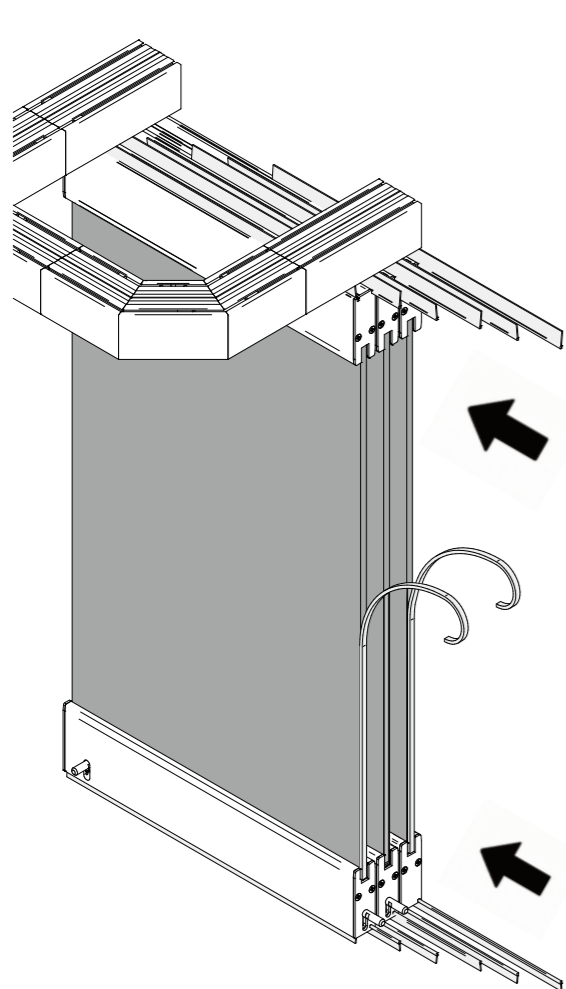

20 mm

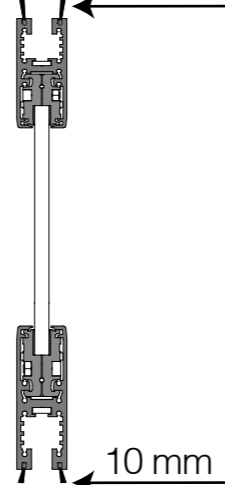

10 mm

Pulire con apposita salvietta prima dell'applicazione.
Clean with a special towel before application.
Limpiar con una toalla especial antes de la aplicación.



Non installare su vetro freddo
Do not install on cold glass
No instalar sobre vidrio frío

14 Installazione pozzetti a pavimento - Assembly floor bush - Montaje casquillo de fondo

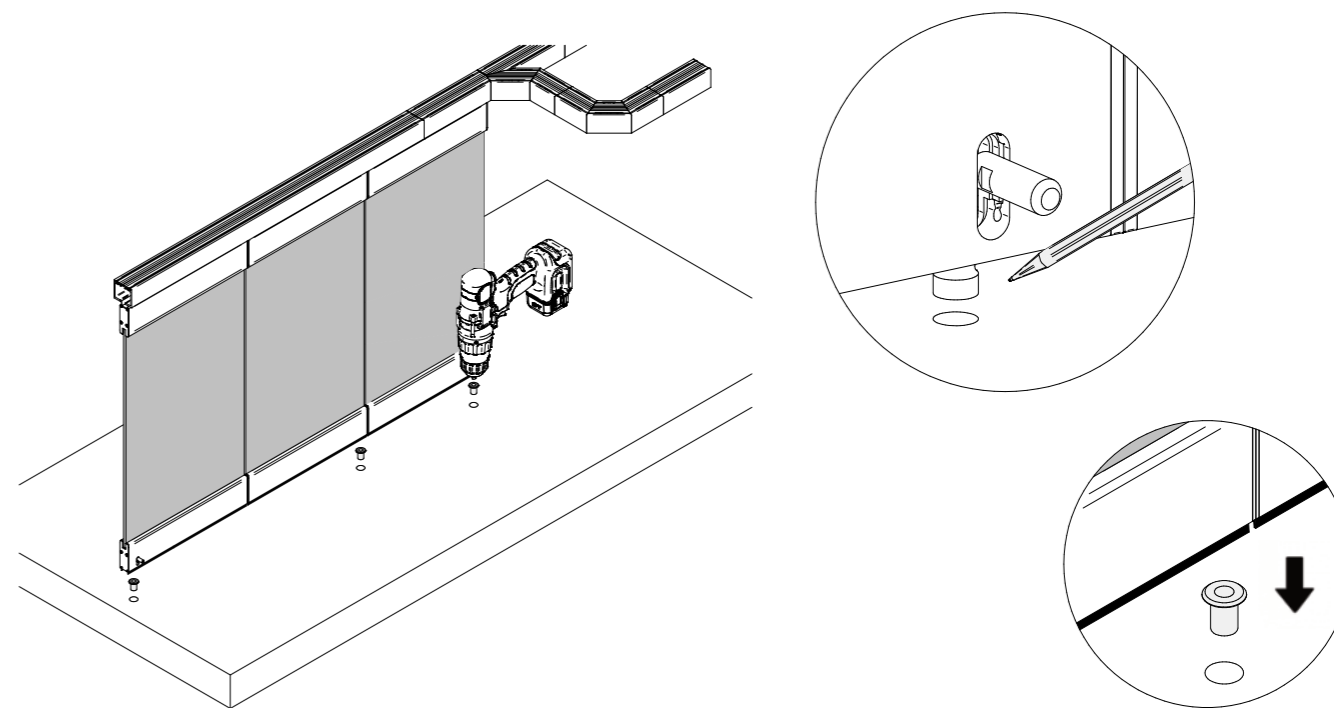

15 Installazione dell'anta "A" - Panels mounting "A" - Instalación de hoja "A"

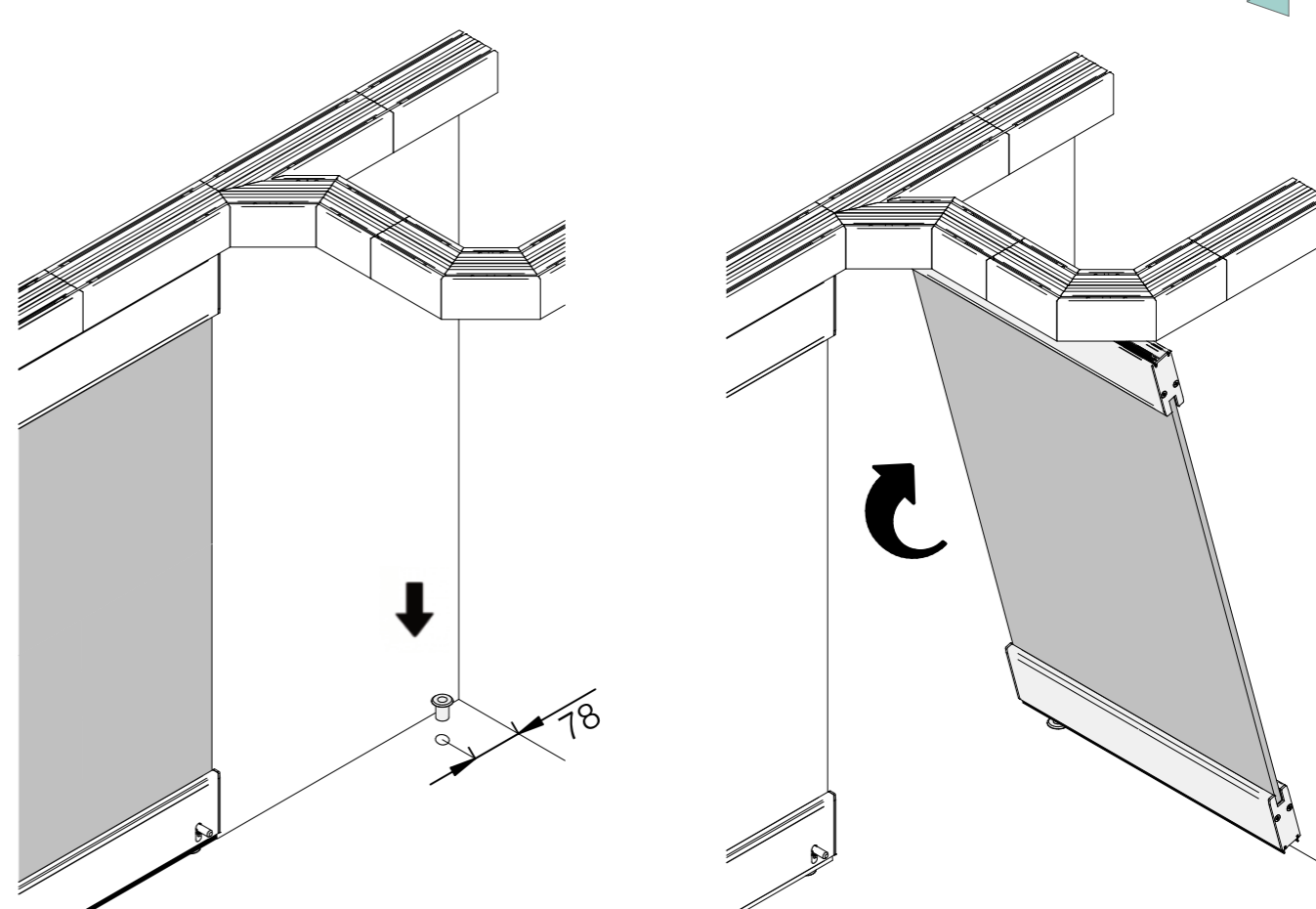

Aprire la porta battente accompagnandola
 Open the swing door by accompanying it
 Abre la puerta batiente acompañándola

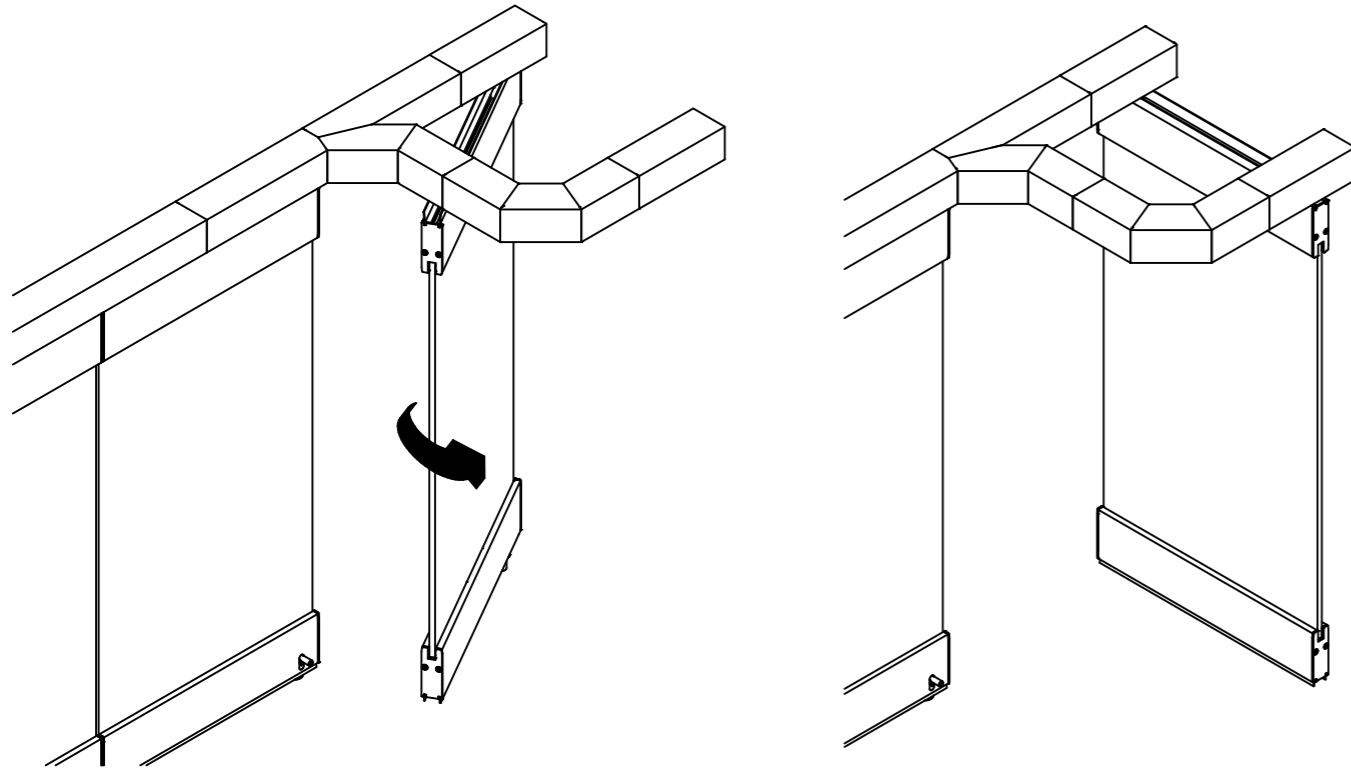

Per movimentare la prima anta azionare il cricchetto per liberare l'anta e movimentarla tenendola da entrambe le estremità fino alla zona di parcheggio.

To move the first leaf, operate the latch to release the leaf and move it by holding it from both ends up to the parking area

Para mover la primera hoja, accionar el cerrojo para liberar la hoja y moverla sujetándola por ambos extremos hasta la zona de estacionamiento

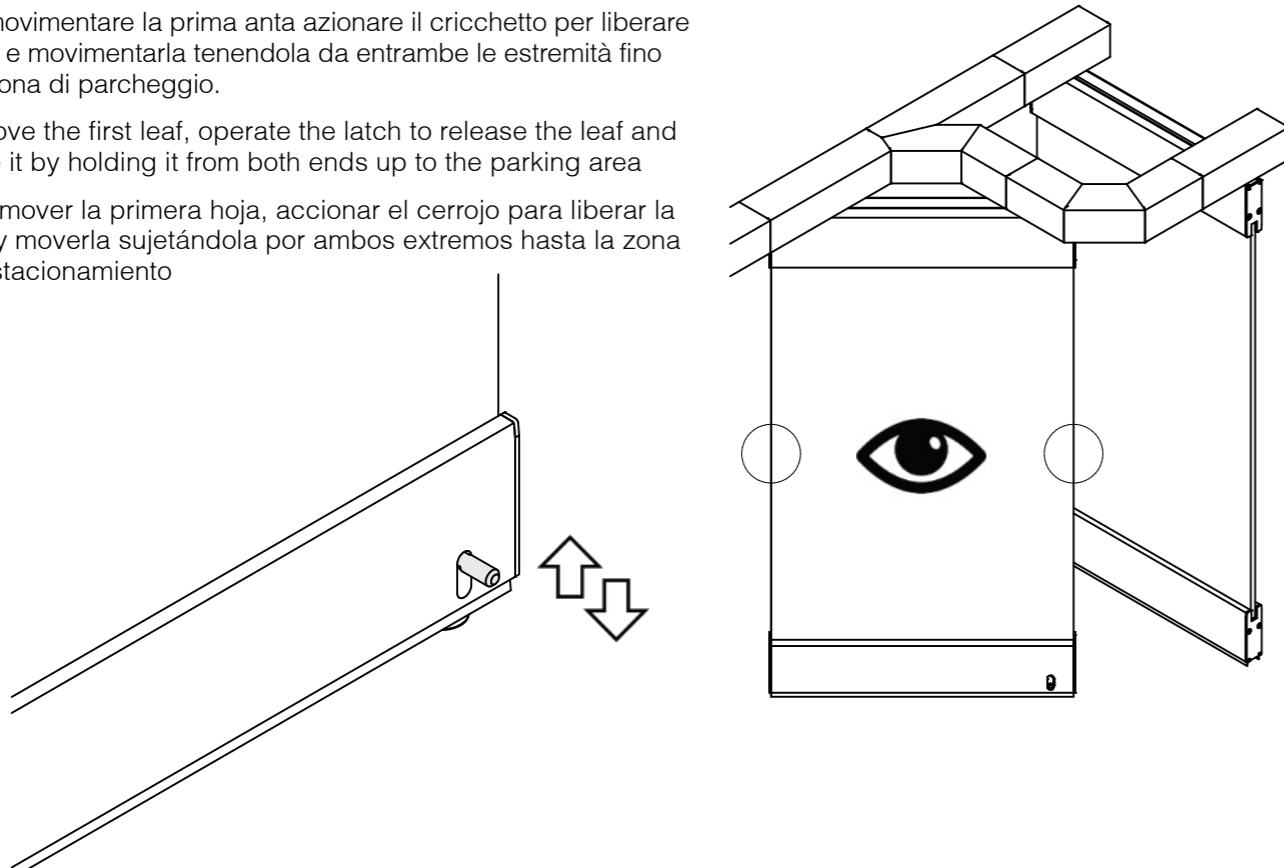

Per movimentare le ante intermedie azionare il cricchetto per liberare l'anta e movimentarla tenendola da entrambe le estremità fino alla zona di parcheggio.

To move the intermediate leaves, operate the latch to free the door and move it by holding it from both ends up to the parking area

Para mover las hojas intermedias accionar el cerrojo para liberar la puerta y moverla sujetándola por ambos extremos hasta la zona de estacionamiento

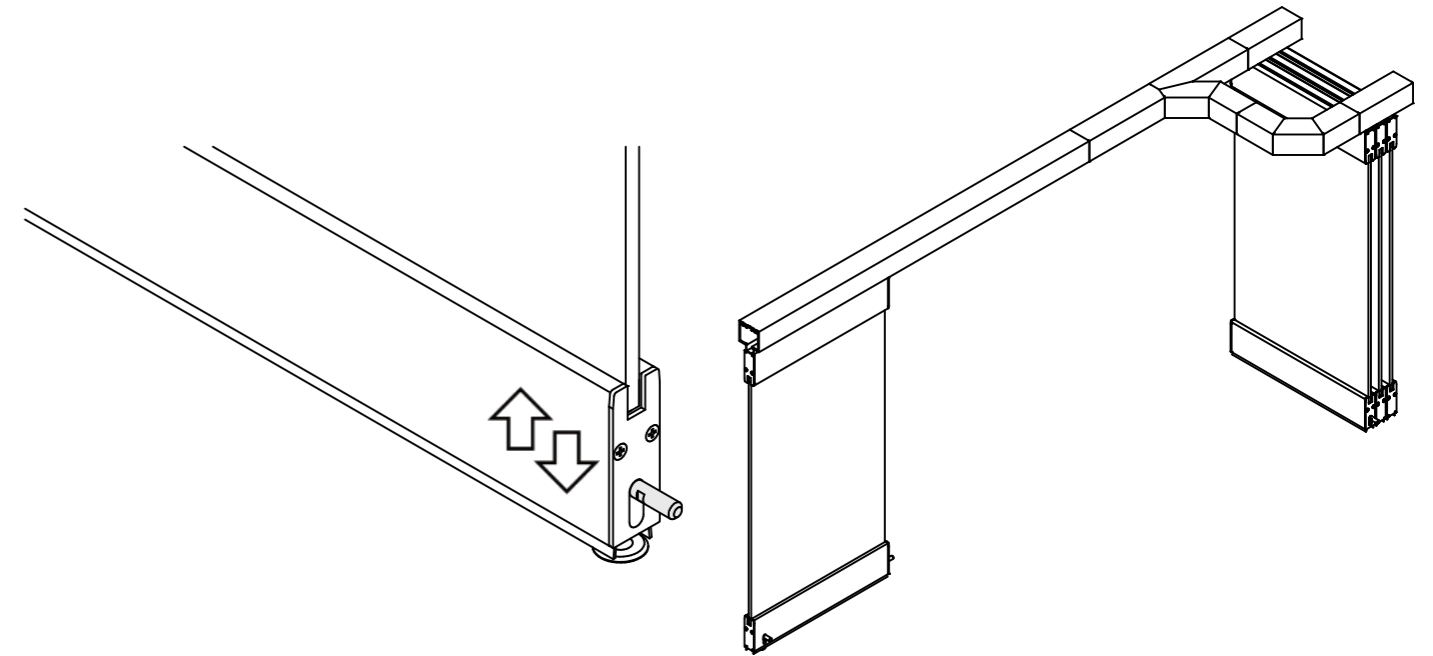

Per movimentare l'ultima anta azionare i cricchetti per liberare l'anta e movimentarla tenendola da entrambe le estremità fino alla zona di parcheggio.

To move the last leaf, operate the latch to free the leaf and move it by holding it from both ends up to the parking area.

Para mover la última hoja, accione los cerrojos para liberar la hoja y muévala sujetándola por ambos extremos hacia el área de estacionamiento.

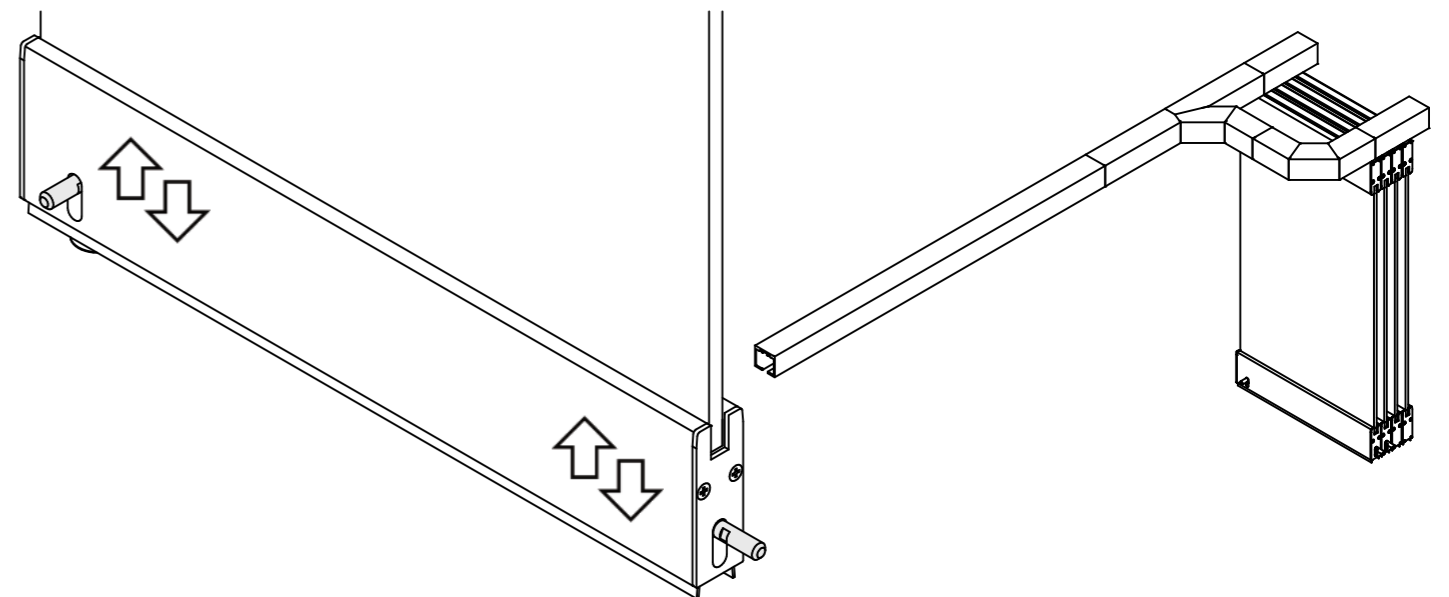

USO E MANUTENZIONE - PARKING

Per garantire un corretto funzionamento pulire le spazzole da sporco e polvere. Verificare che non ci siano corpi estranei in corrispondenza dei pozzetti che potrebbero impedire il bloccaggio dell'anta.

To ensure correct operation, clean the brushes from dirt and dust. Check that there are no foreign bodies in correspondence wells that could prevent the door from locking.

Verificar que no hayan cuerpos extraños dentro de los dedales inferiores que puedan impedir el bloque de la puerta.

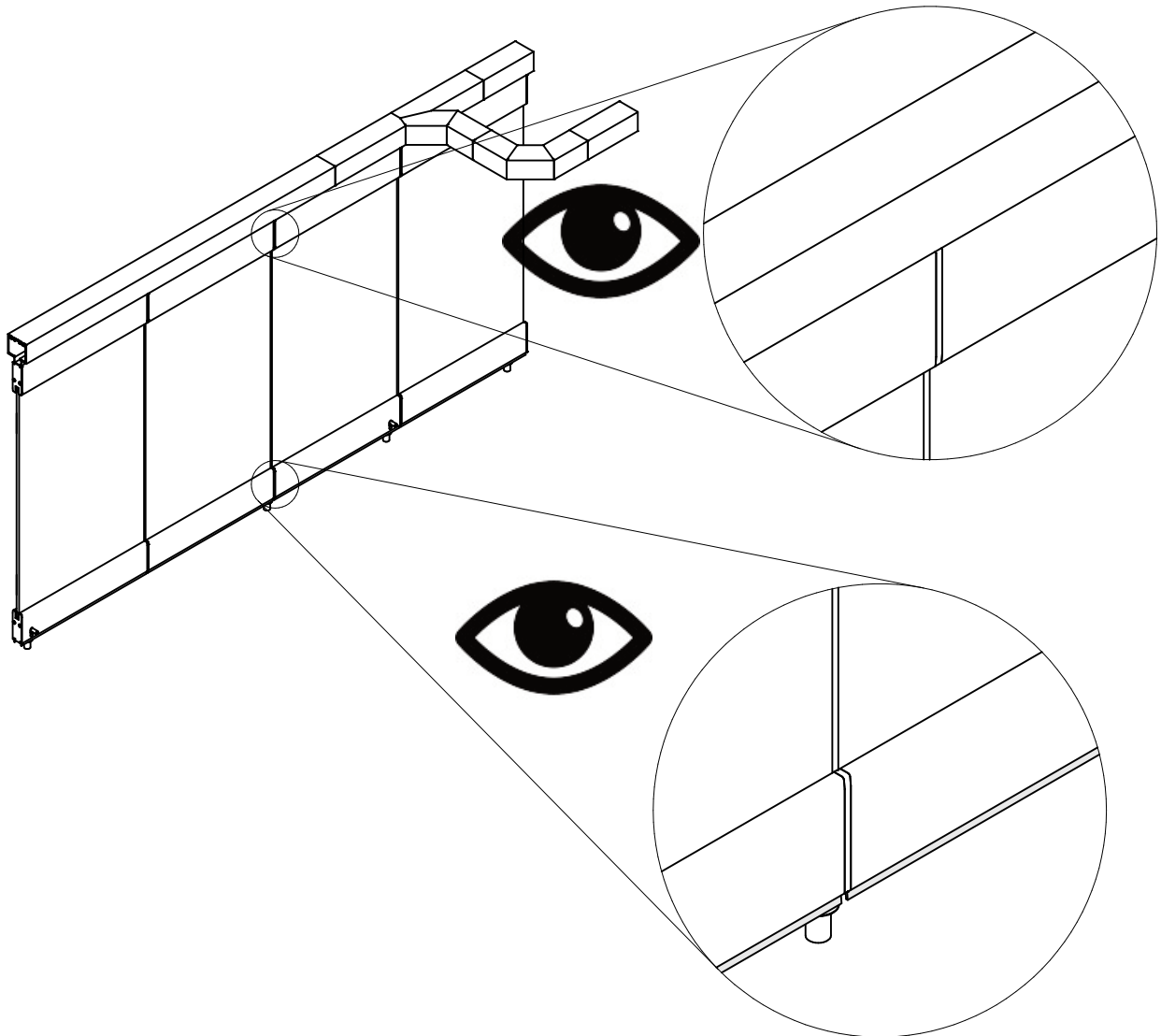

Seguici sui Social Media
Siguenos en redes



Mc-Slide s.r.l. - [mcslide.it](https://www.mcslide.it) - info@mcslide.it
Mc-Slide Spain - [mcslide.es](https://www.mcslide.es) - info@mcslide.es