



M C  
SLIDE

Mc-Slide s.r.l.  
☎ mcslide.it  
✉ info@mcslide.it

Mc-Slide Spain -  
☎ mcslide.es  
✉ info@mcslide.es

# GIBLI QUADRO MURO-MURO



FEB-2014

038

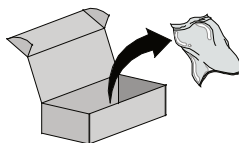

|   |  |   |   |  |   |
|---|--|---|---|--|---|
| a |  | 2 | e |  | 2 |
| b |  | 2 | f |  | 1 |
| c |  | 2 | g |  | 1 |
| d |  | 2 | h |  | 1 |
|   |  |   | i |  | 2 |

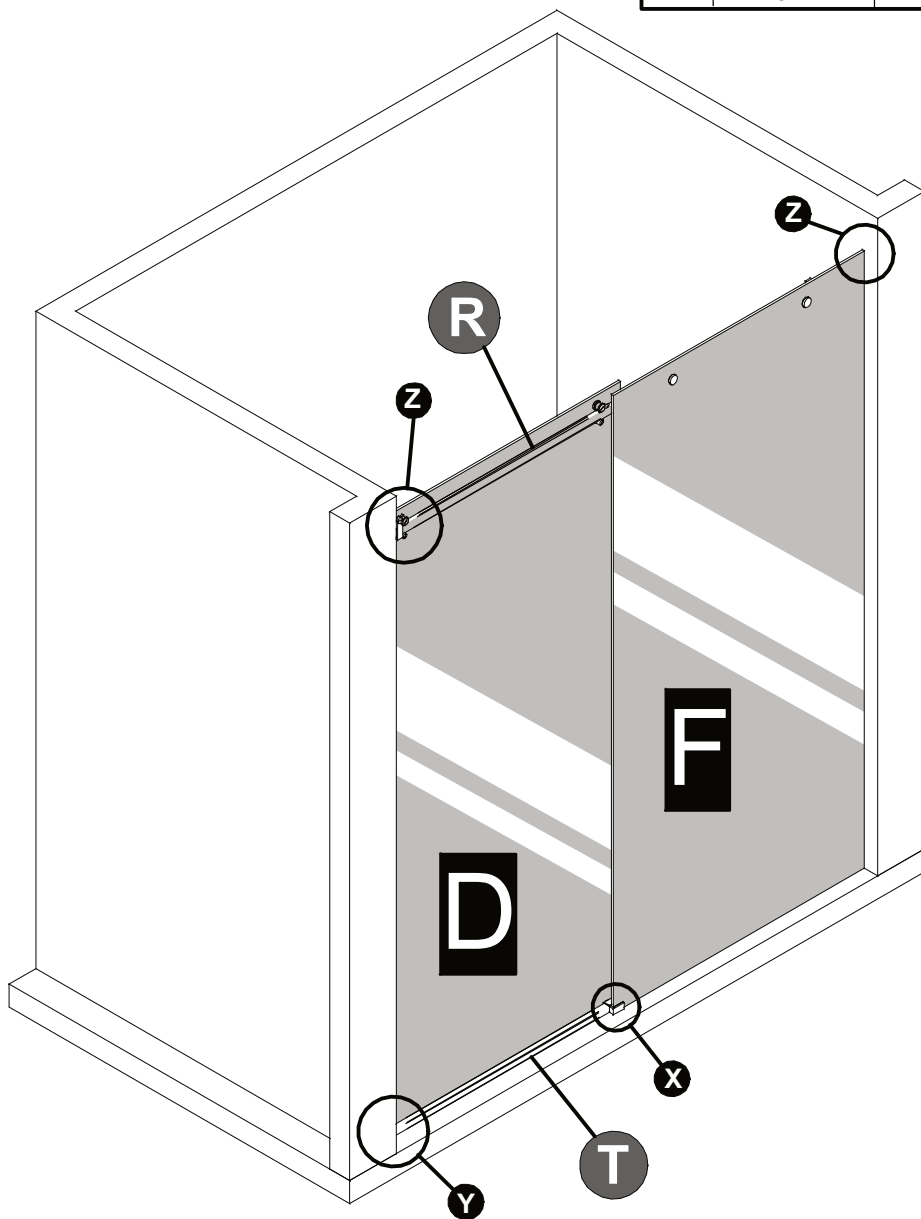
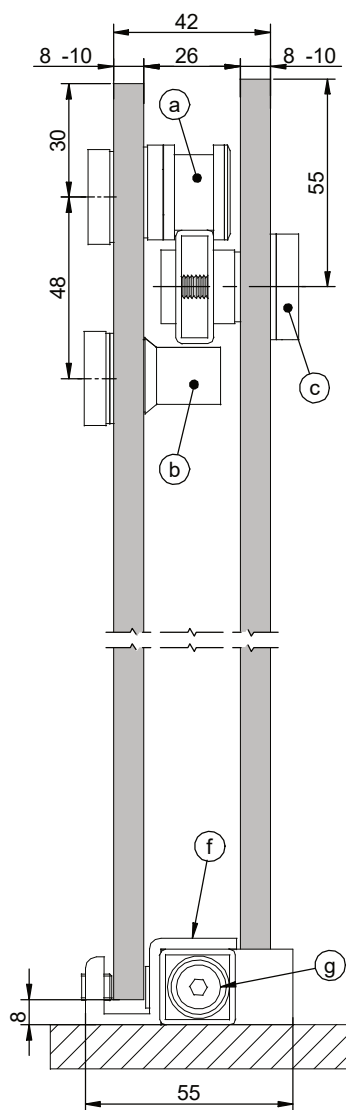
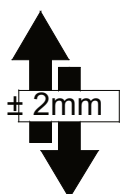

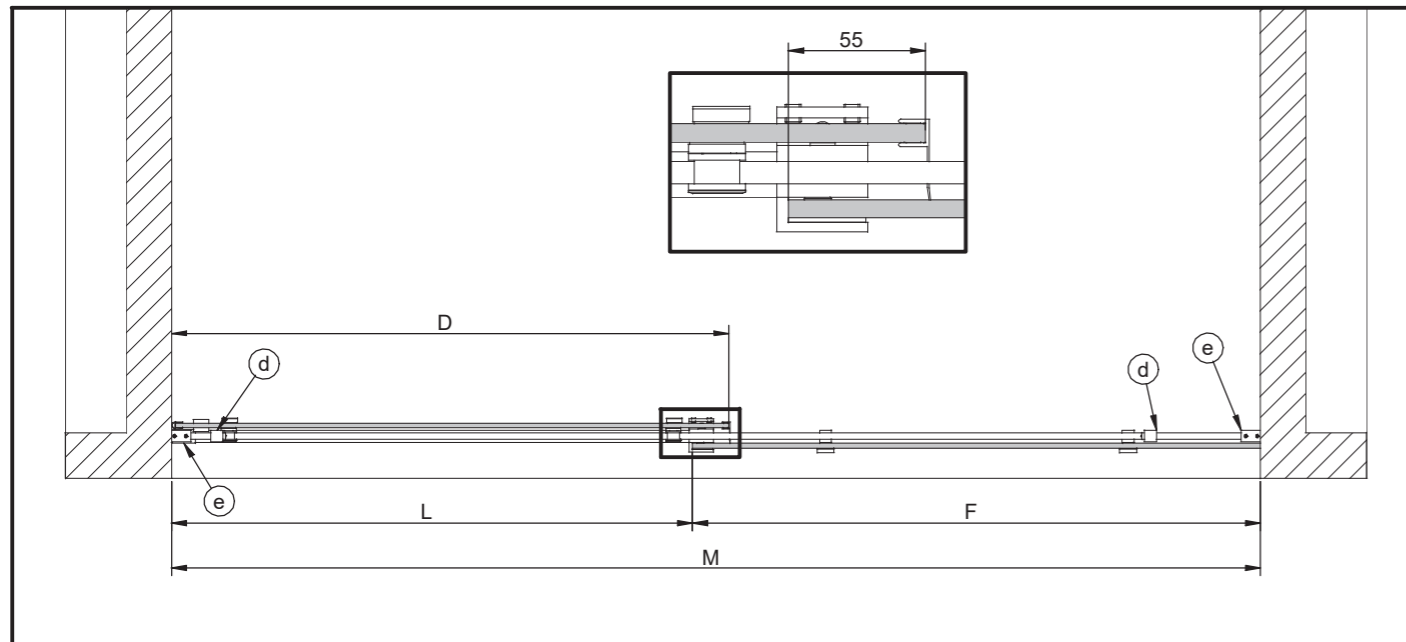

**INSTALLAZIONE CON VETRI A RASO**  
 Levelled assembly  
 Mountage arasé

**M = Max. 1800mm.**  
**L = Min. 450mm**  
**D = L + 55mm.**  
**F = M - L mm.**

**M = Max. 1800mm**  
**L = Min. 450mm**  
**D =  $\frac{M + S + 55mm}{2}$**   
**F = M - L mm.**

**INSTALLAZIONE CON SORMONTO MANIGLIA**  
 Overlap assembly  
 Mountage Sournois

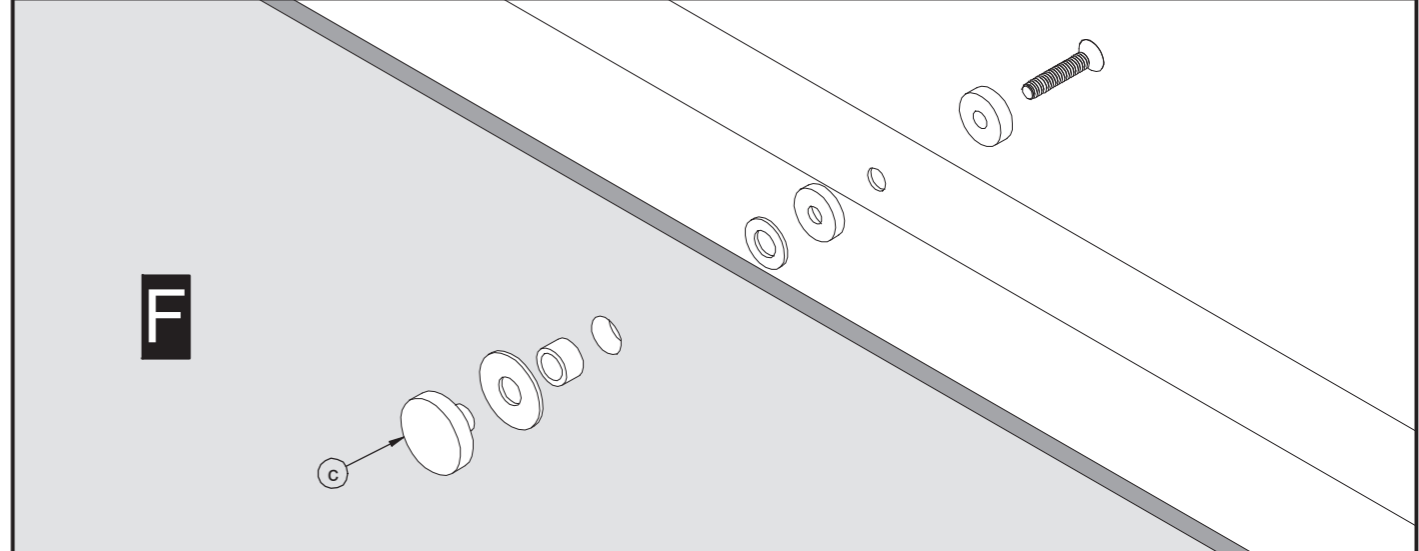
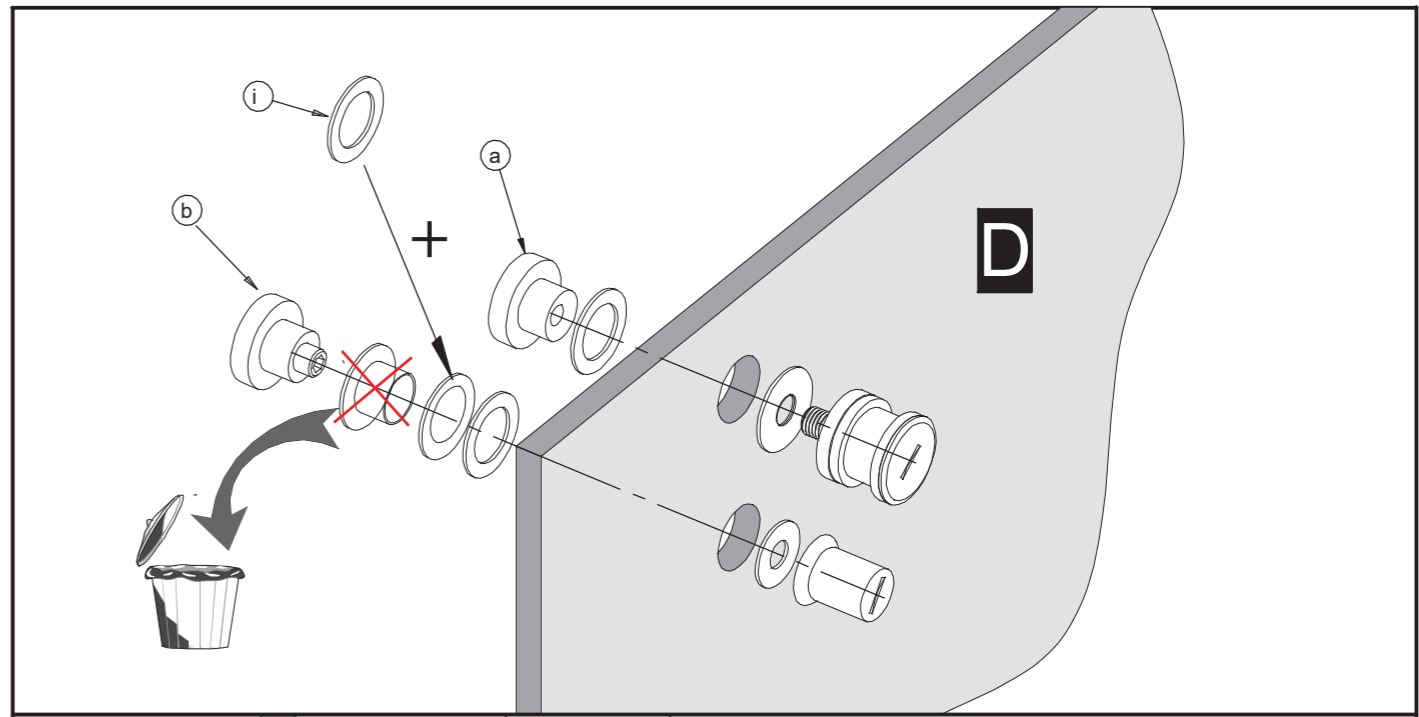
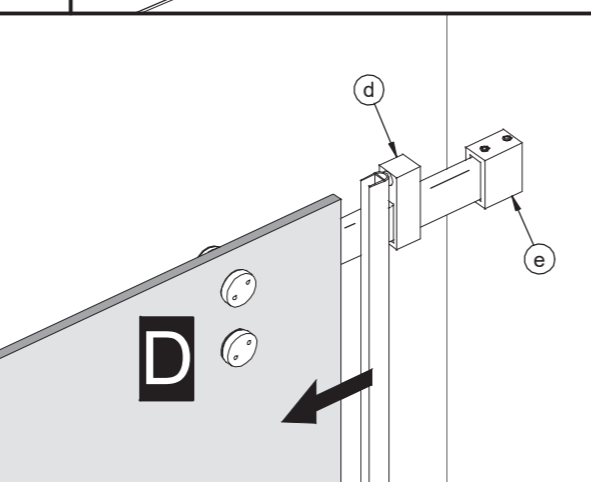
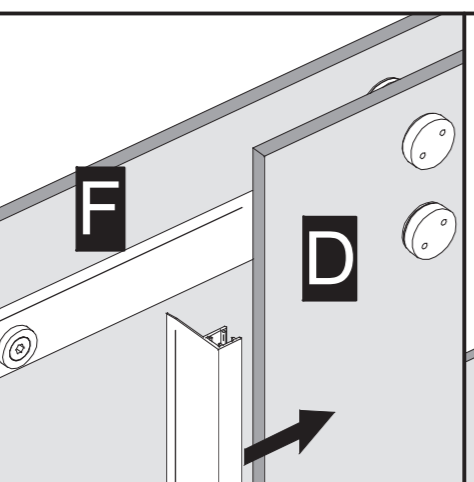
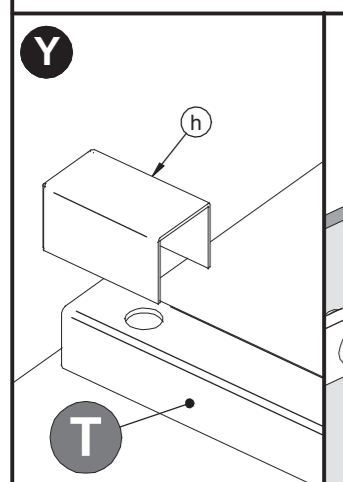
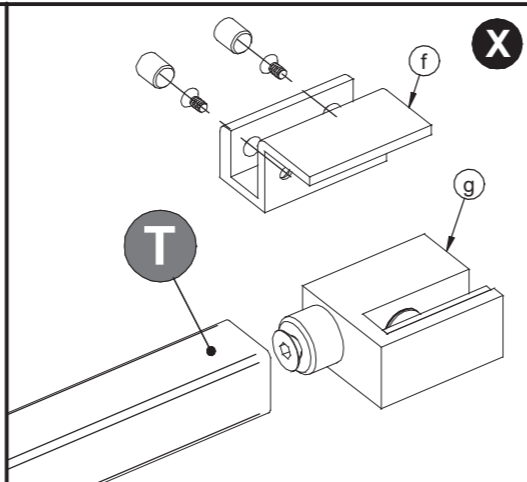
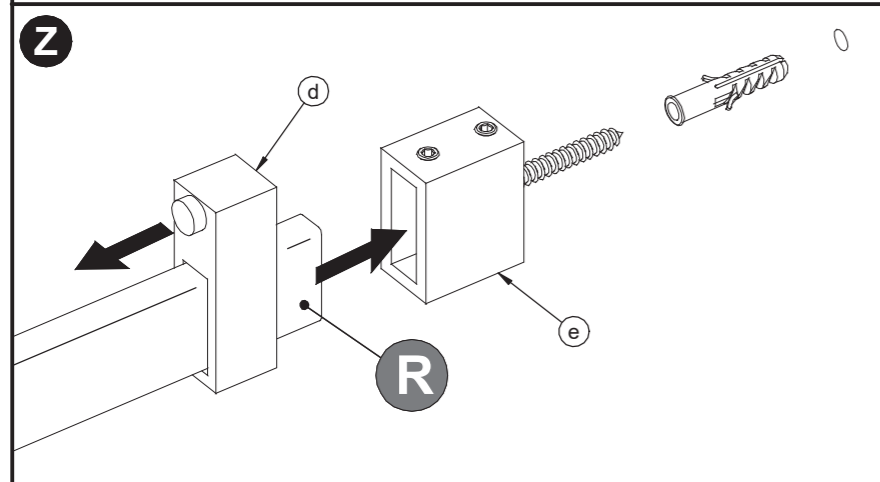
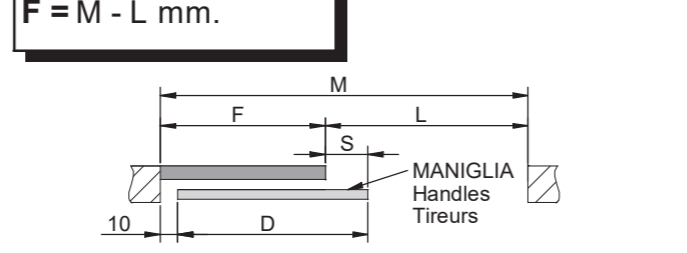
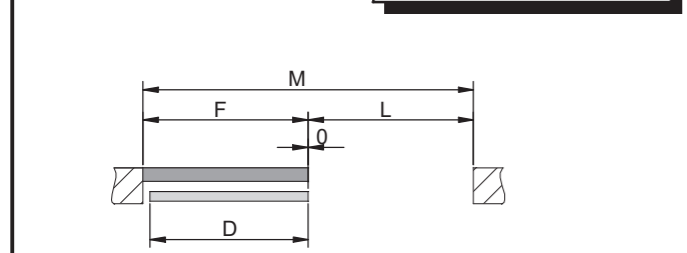

**LVORAZ. PROFILO**  
 Profile preparation  
 Usinage des perfiles

**TAGLIARE COME RICHIESTO**  
 cut on two sides to adjust  
 couper sur les deux côtés pour ajuster

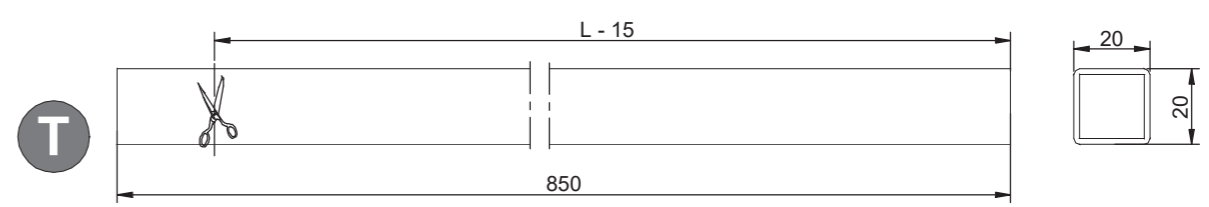
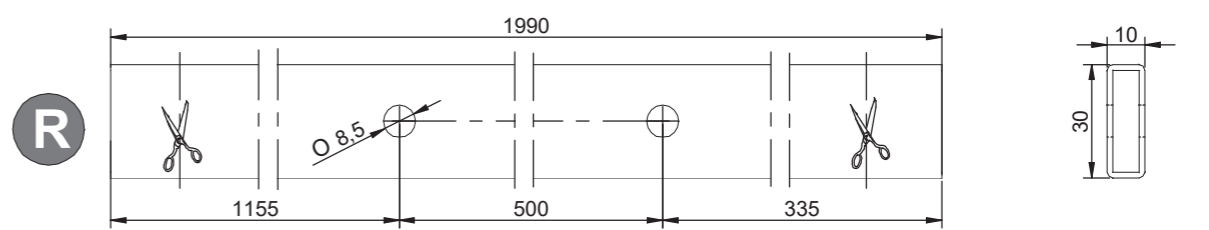

**TAGLIARE COME RICHIESTO**  
 cut on one side to adjust  
 coupé sur un côté pour ajuster

**LAVORAZIONE DEL VETRO**  
Glass preparation / Usinage des portes

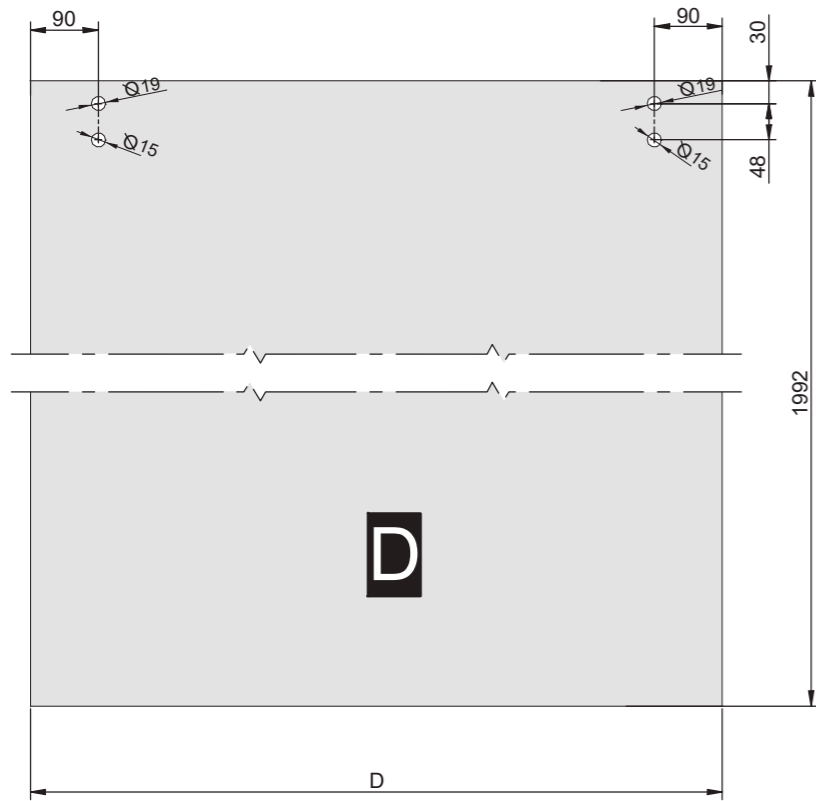

**PORTA SCORREVOLE**  
SLIDING DOOR  
PORTE COULISSANTE

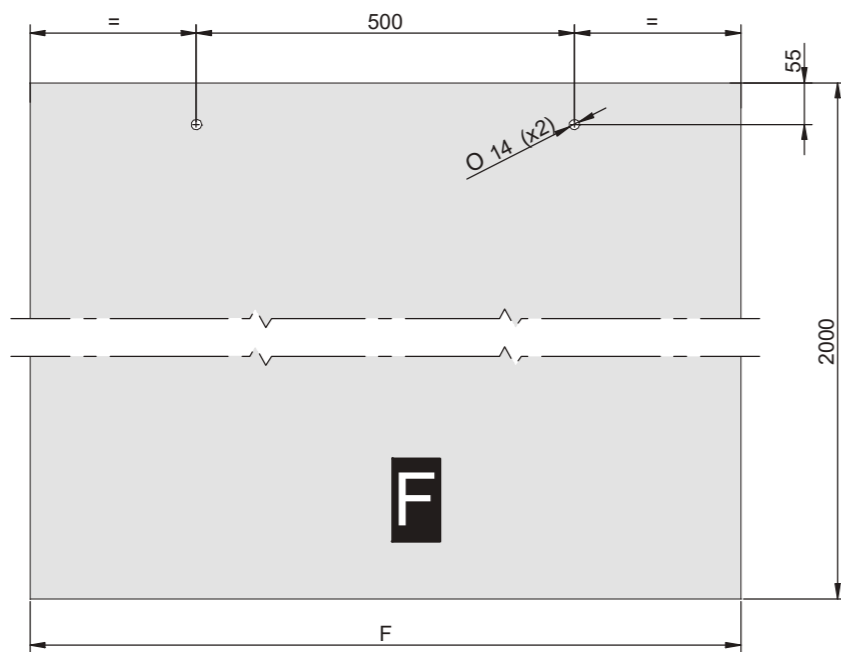

**VETRO FISSO**  
FIXED GLASS  
VERRE FIXE

Seguici sui Social Media  
Siguenos en redes



Mc-Slide s.r.l. - [mcslide.it](http://mcslide.it) - [info@mcslide.it](mailto:info@mcslide.it)  
Mc-Slide Spain - [mcslide.es](http://mcslide.es) - [info@mcslide.es](mailto:info@mcslide.es)



**GIBLI QUADRO**  
MURO-VETRO

Mc-Slide s.r.l.  
[mcslide.it](http://mcslide.it)  
[info@mcslide.it](mailto:info@mcslide.it)

Mc-Slide Spain -  
[mcslide.es](http://mcslide.es)  
[info@mcslide.es](mailto:info@mcslide.es)



FEB. 2014

038

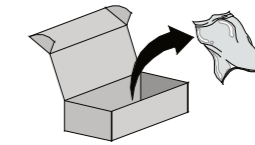

|   |  |   |   |  |   |
|---|--|---|---|--|---|
| a |  | 2 | e |  | 1 |
| b |  | 2 | f |  | 1 |
| c |  | 2 | g |  | 1 |
| d |  | 2 | h |  | 1 |
| i |  | 2 | k |  | 1 |

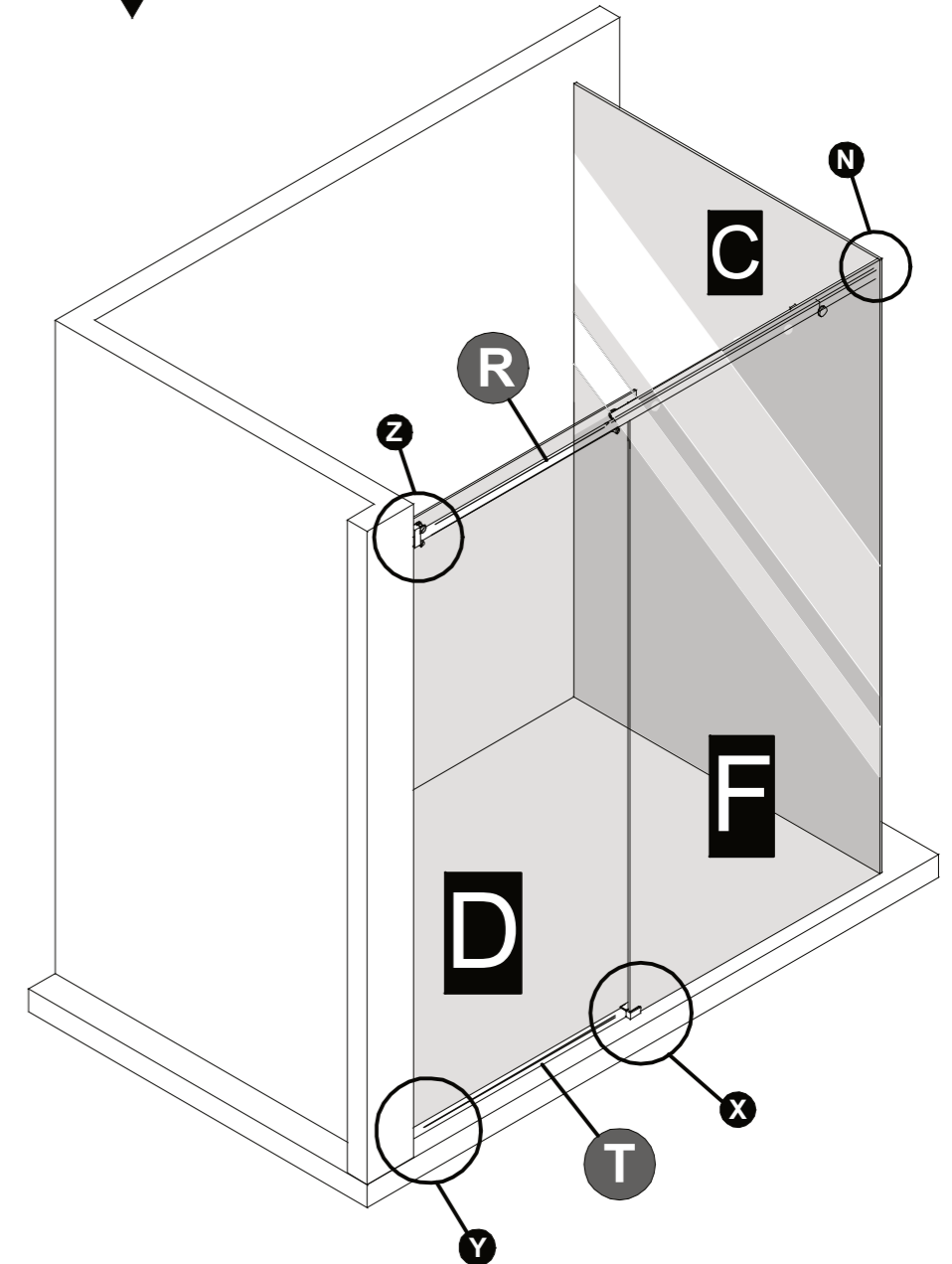
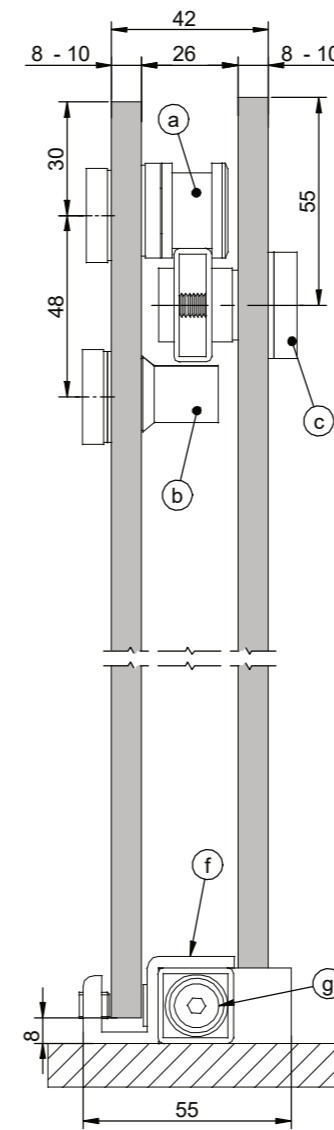

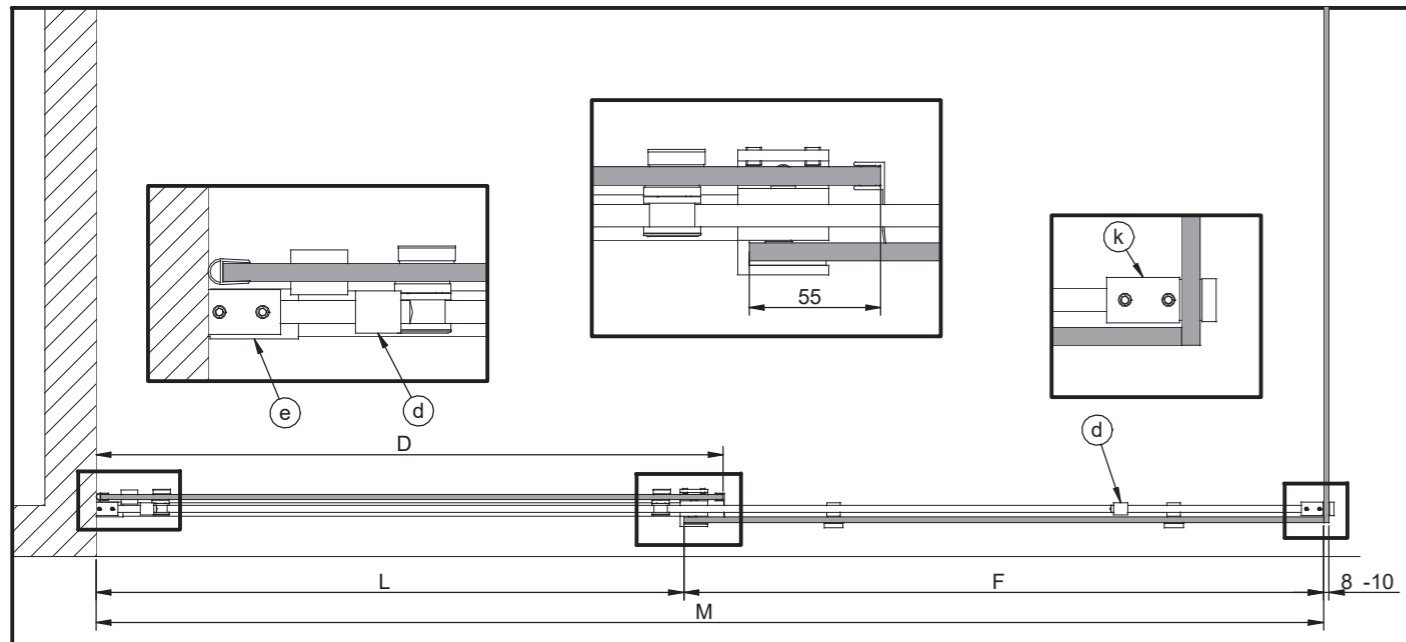

**INSTALLAZIONE CON VETRI A RASO**  
Levelled assembly  
Moutage arasé

**M = Max. 1800mm.**  
**L = Min. 450mm**  
**D = L + 55mm.**  
**F = M - L mm.**

**M = Max. 1800mm**  
**L = Min. 450mm**  
**D =  $\frac{M + S + 55mm}{2}$**   
**F = M - L mm.**

**INSTALLAZIONE CON SORMONTO MANIGLIA**  
Overlap assembly  
Moutage Sournois

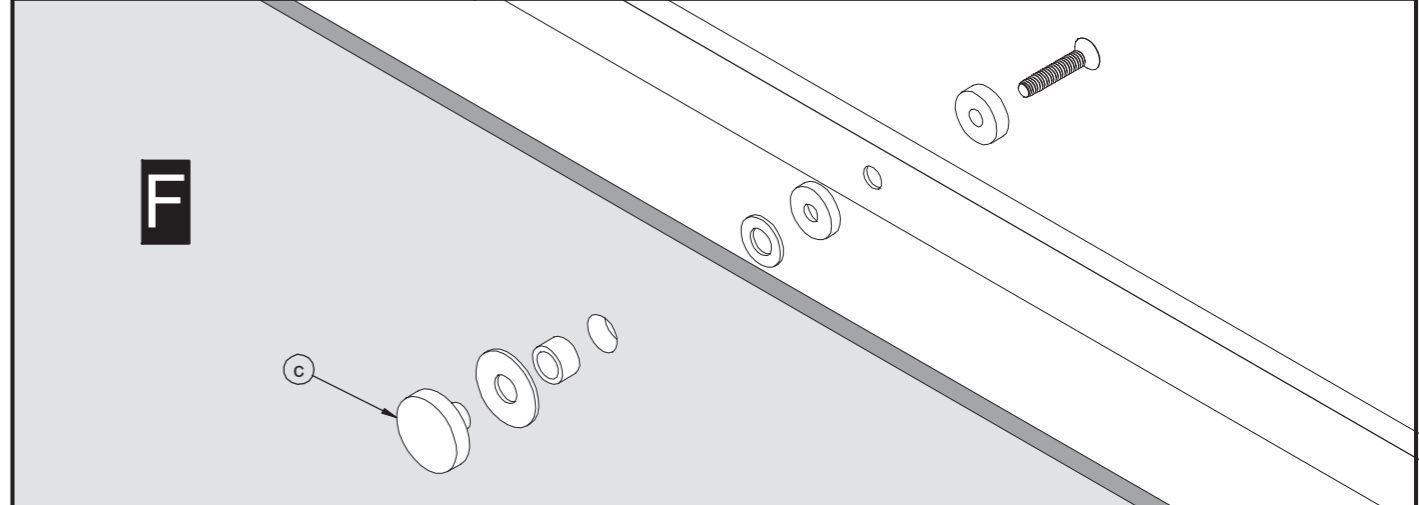
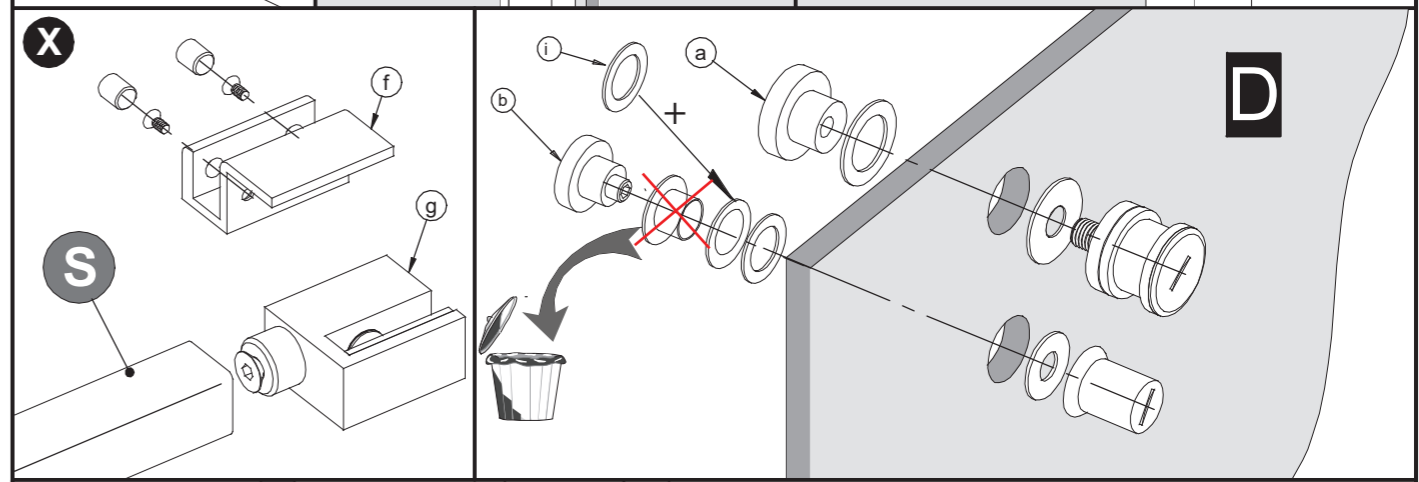
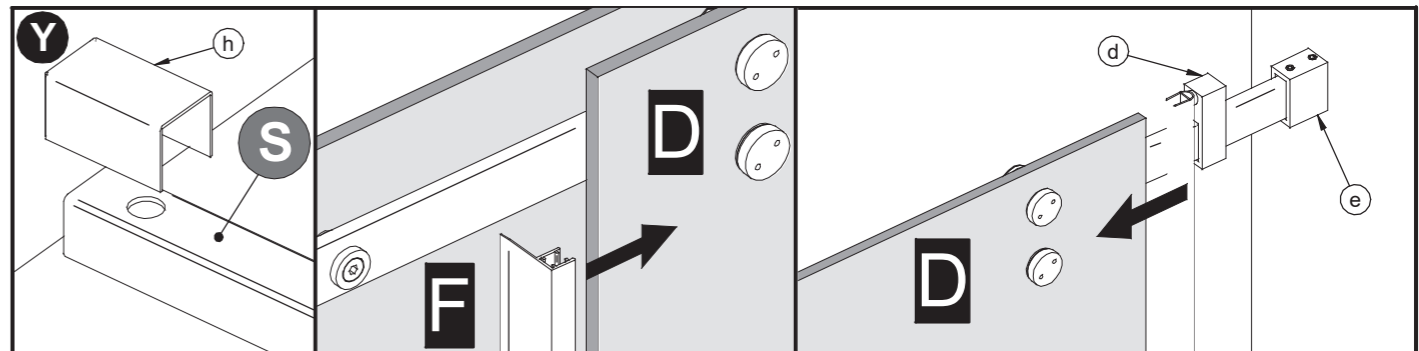
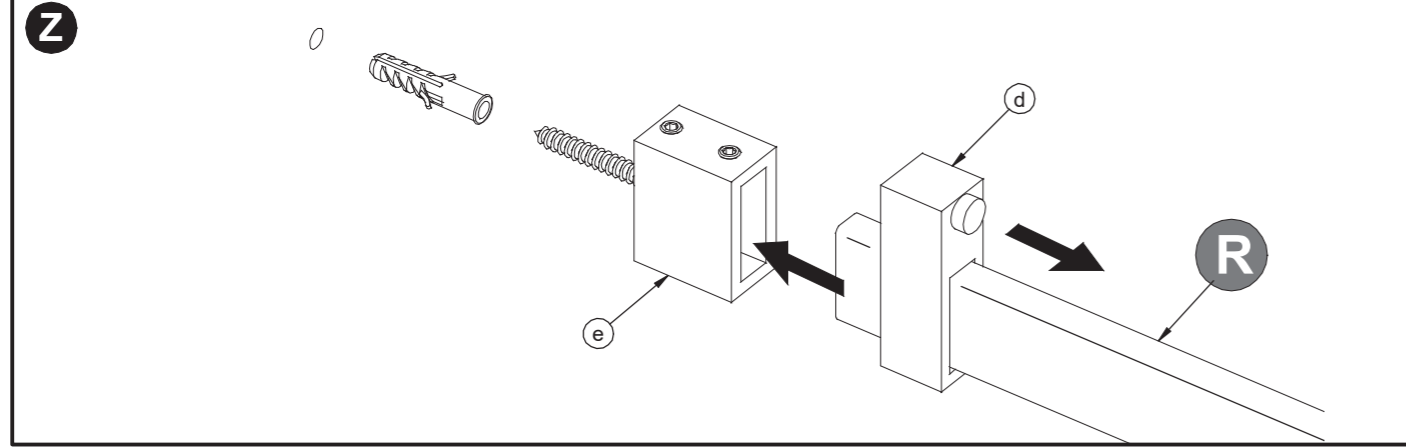
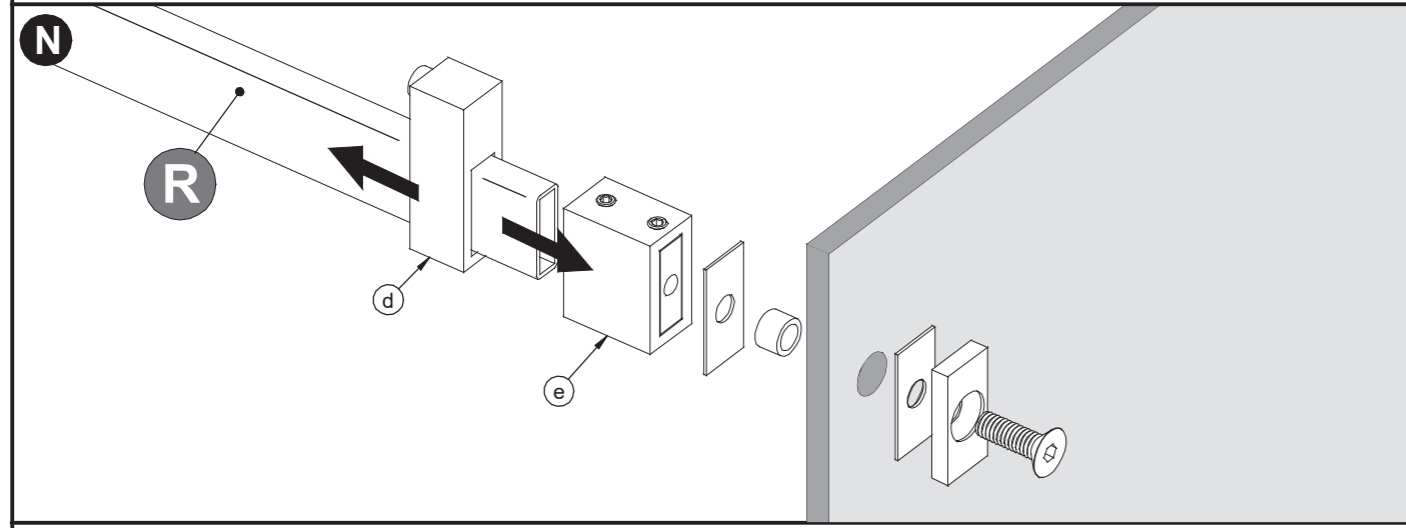
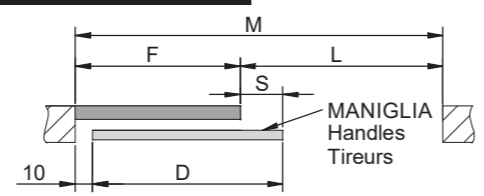
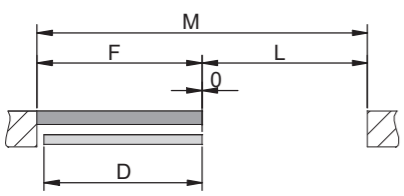

**FORATURA PROFILO**  
Profile preparation  
Usinage des perfiles



**TAGLIARE COME RICHIESTO**  
cut on two sides to adjust  
couper sur les deux côtés pour ajuster

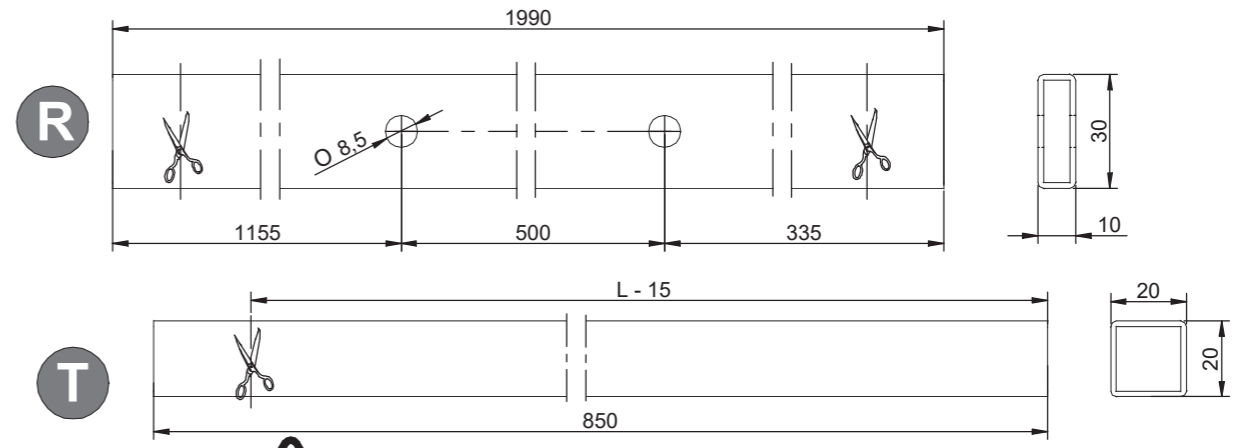

**TAGLIARE COME RICHIESTO**  
cut on one side to adjust  
coupé sur un côté pour ajuster

**FORATURA DEI VETRI**  
Glass preparation / Usinage des portes

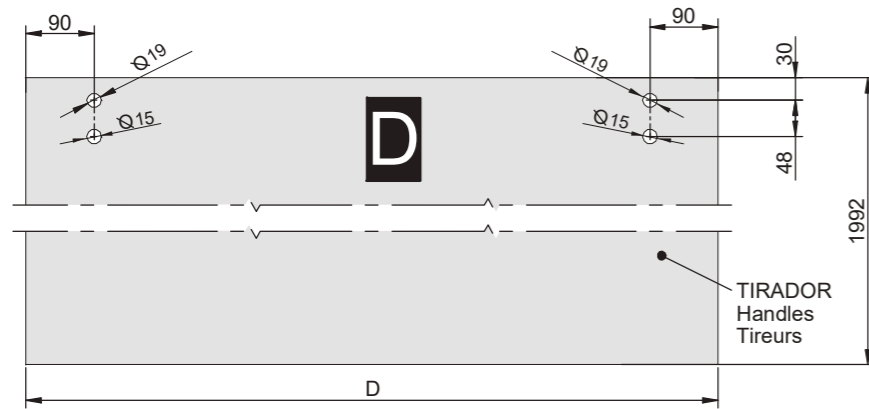

**PORTA SCORREVOLE**  
SLIDING DOOR  
PORTE COULISSANTE

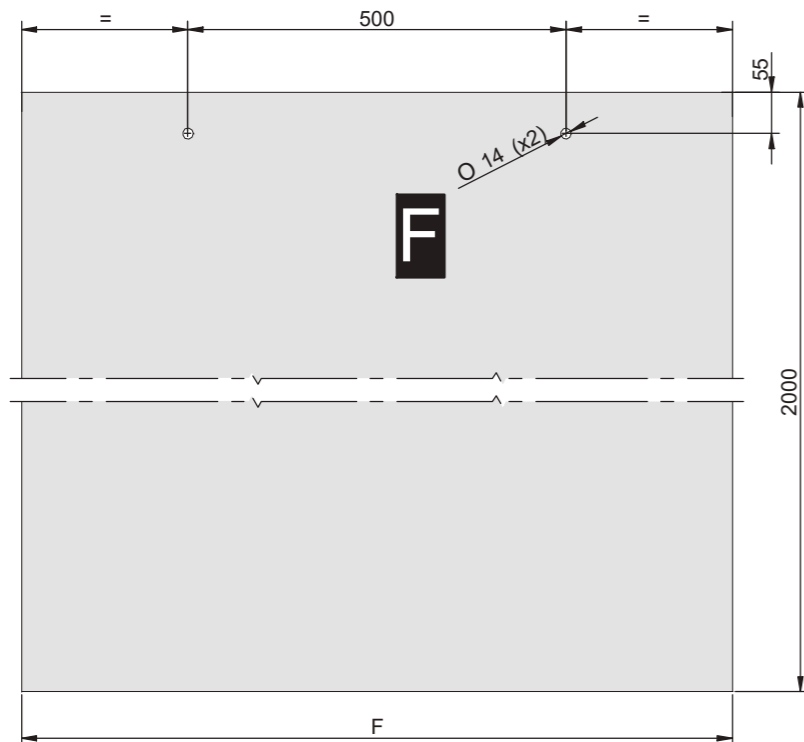

**VETRO FISSO**  
FIXED GLASS  
VERRE FIXE

**FORATURA DEL VETRO LATERALE**  
Side glass machining / Usinage de verr de côté

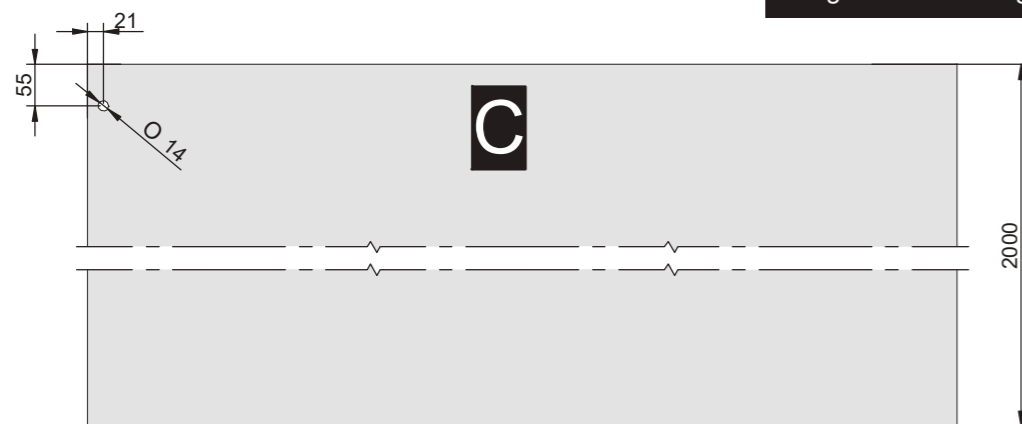

**GHIBLI QUADRO**  
VETRO-VETRO

Mc-Slide s.r.l.  
☎ mcslide.it  
✉ info@mcslide.it  
  
Mc-Slide Spain -  
☎ mcslide.es  
✉ info@mcslide.es



FEB. 2014  
038

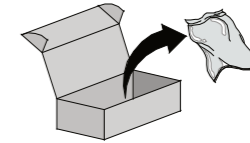

|   |  |   |   |  |   |
|---|--|---|---|--|---|
| a |  | 2 | e |  | 2 |
| b |  | 2 | f |  | 1 |
| c |  | 2 | g |  | 1 |
| d |  | 2 | h |  | 1 |
|   |  |   | i |  | 2 |

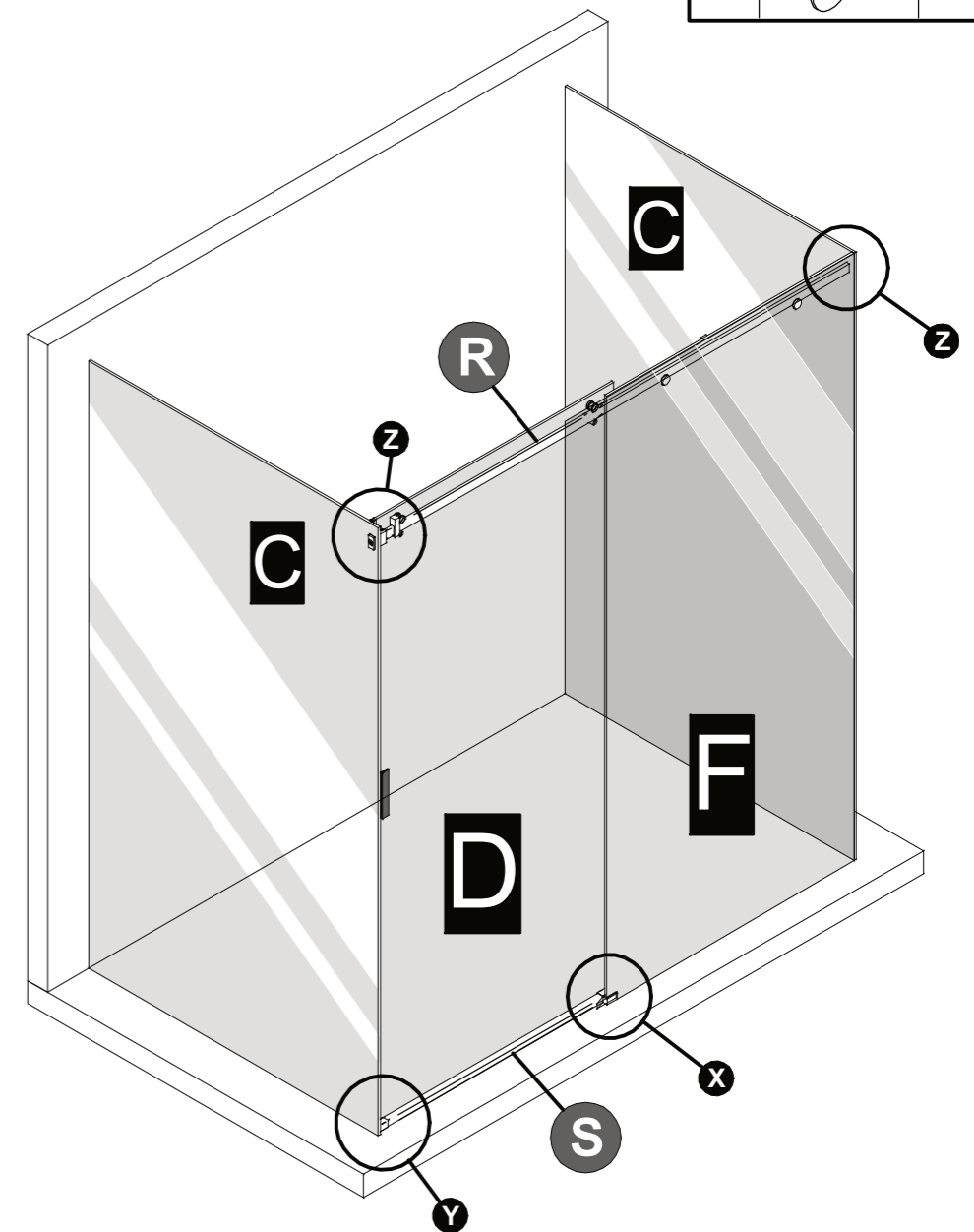
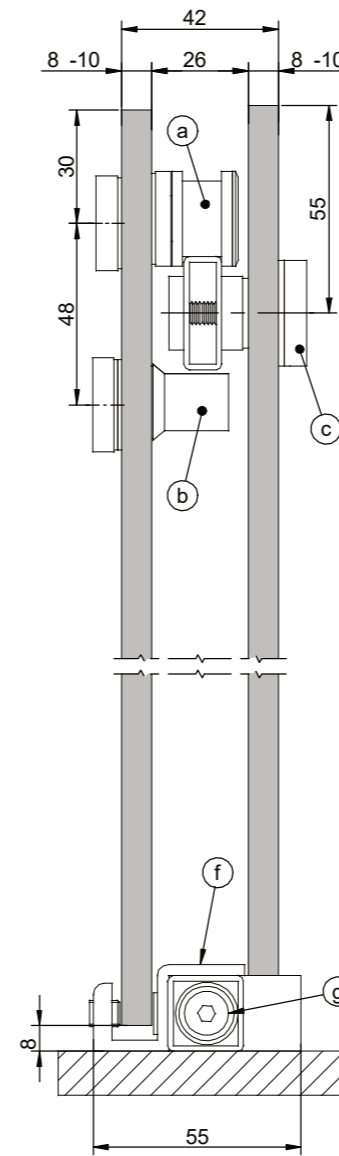
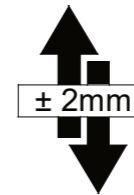

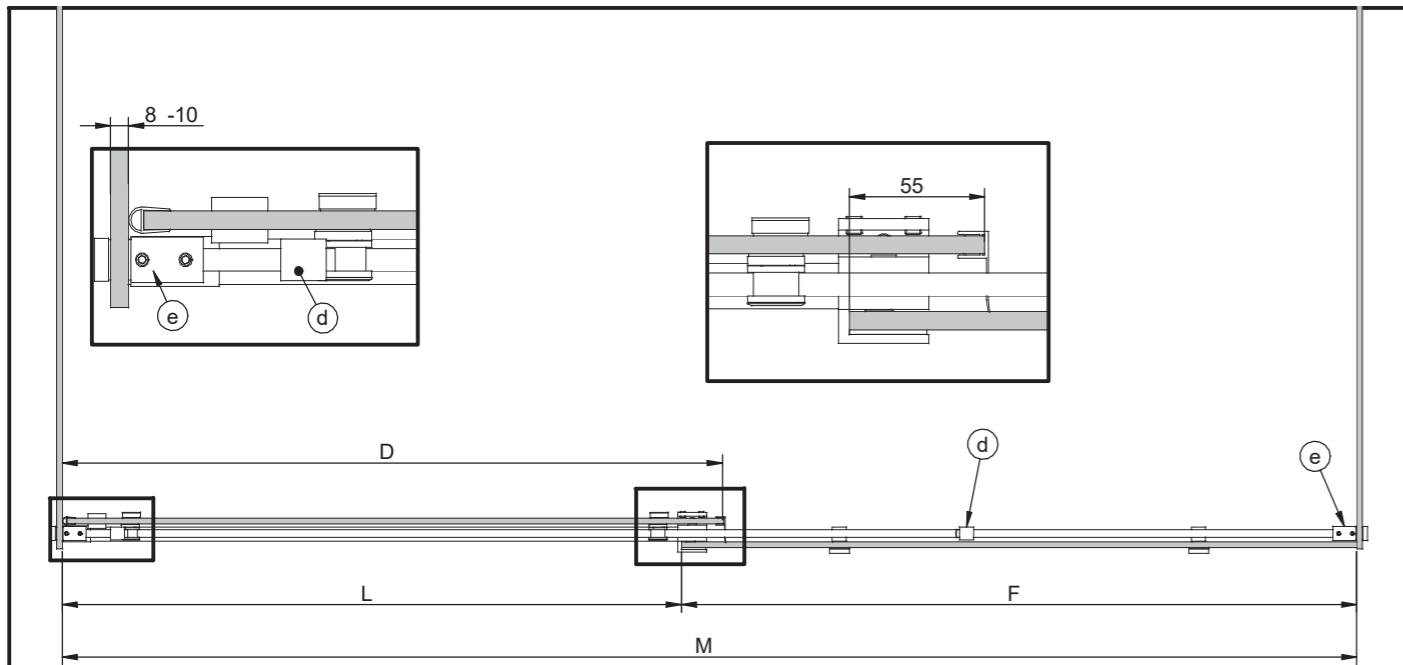

**INSTALLAZIONE CON VETRI A RASO**  
 Leveled assembly  
 Mountage arasé

**M = Max. 1800mm.**  
**L = Min. 450mm**  
**D = L + 55mm.**  
**F = M - L mm.**

**M = Max. 1800mm**  
**L = Min. 450mm**  
**D =  $\frac{M + S + 55mm}{2}$**   
**F = M - L mm.**

**INSTALLAZIONE CON SORMONTO MANIGLIA**  
 Overlap assembly  
 Mountage Sournois

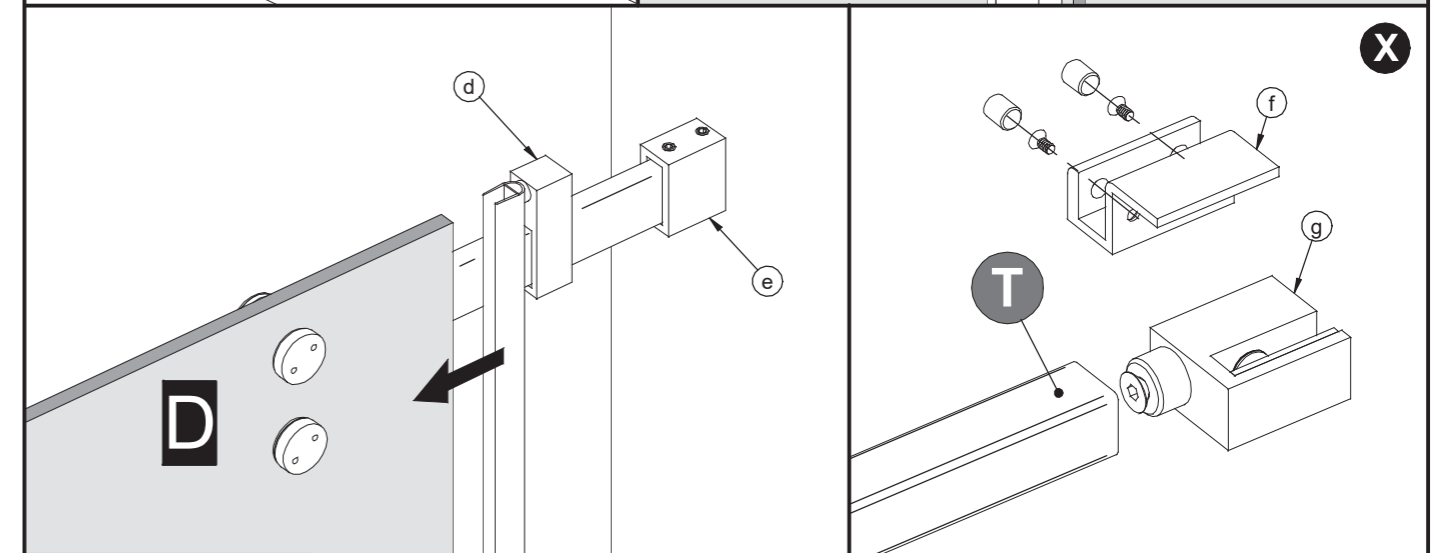
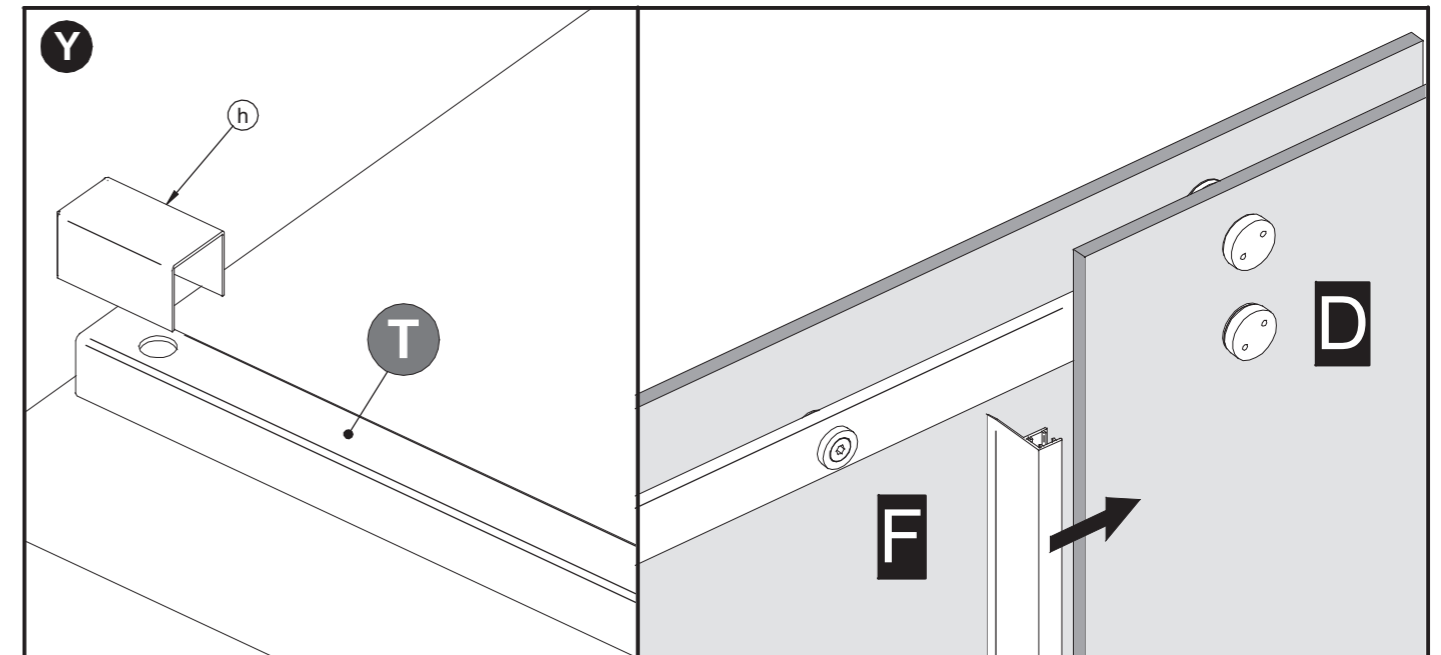
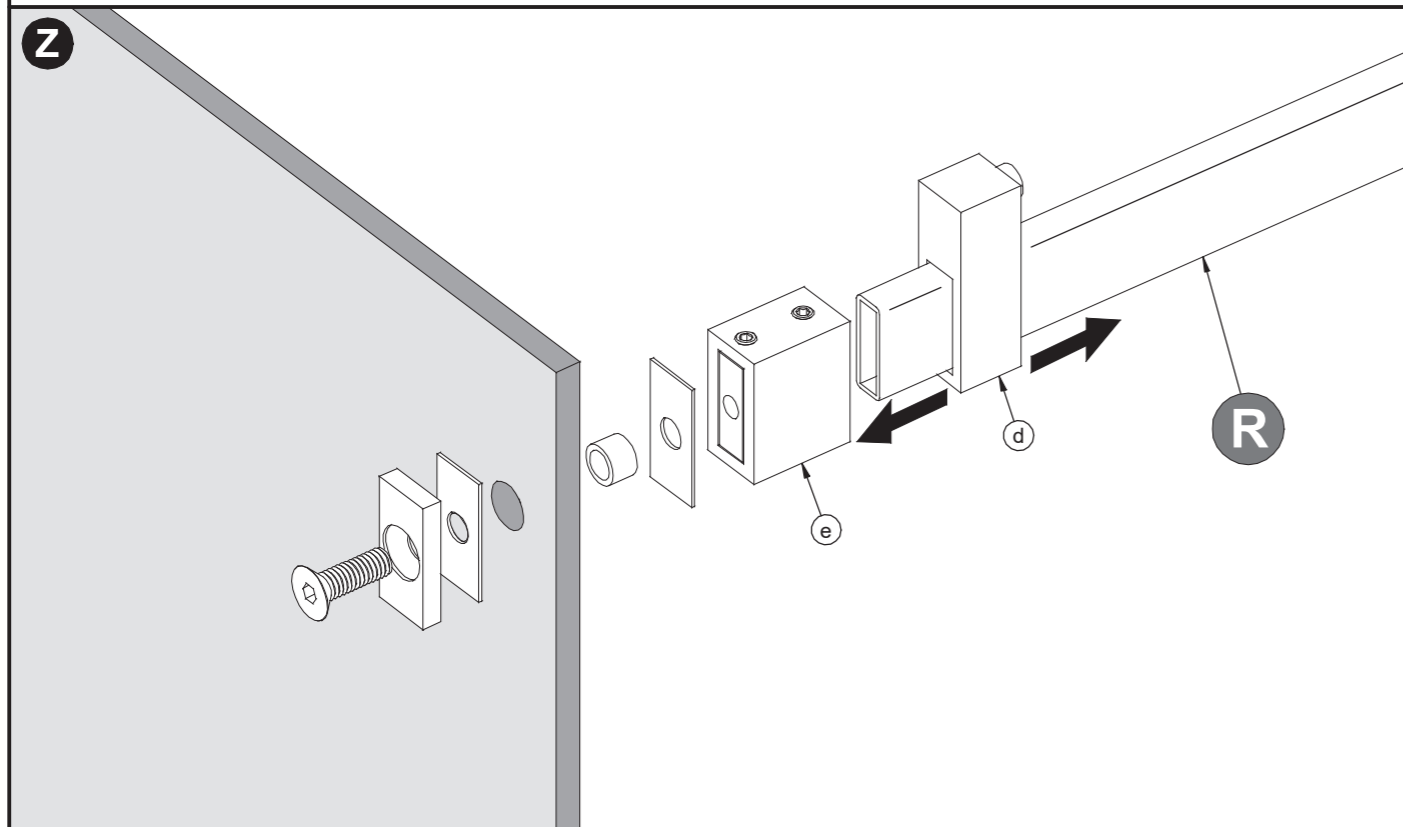
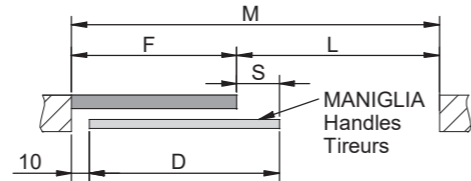
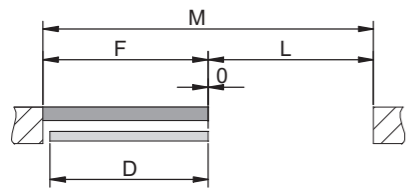

**FORATURA PROFILO**  
 Profile preparation  
 Usinage des perfiles



**TAGLIARE COME RICHIESTO**  
 cut on two sides to adjust  
 couper sur les deux côtés pour ajuster

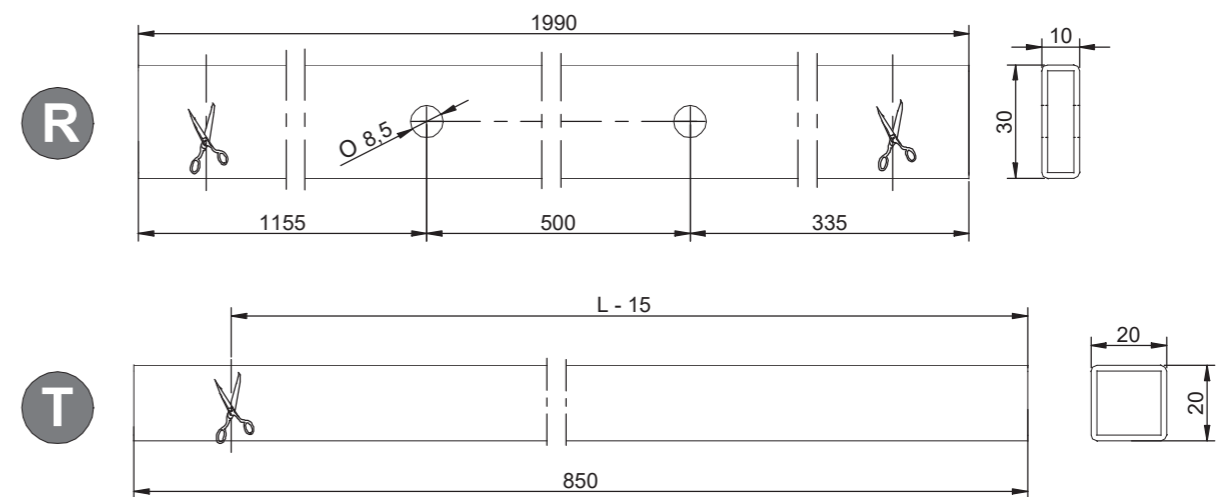

**TAGLIARE COME RICHIESTO**  
 cut on one side to adjust  
 coupé sur un côté pour ajuster

**FORATURE DEI VETRI**  
Glass preparation / Usinage des portes

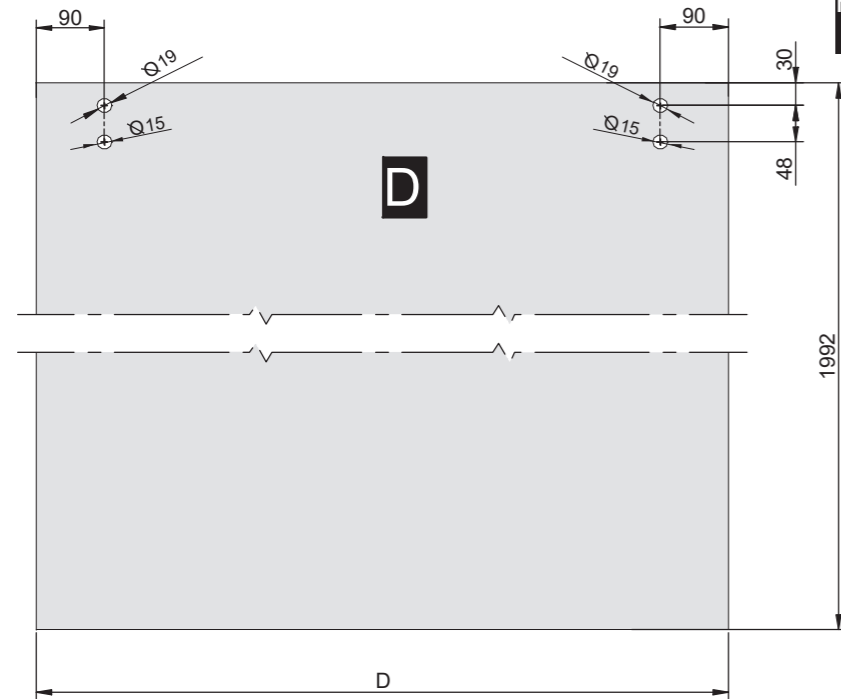

**PORTA SCORREVOLE**  
SLIDING DOOR  
PORTE COULISSANTE

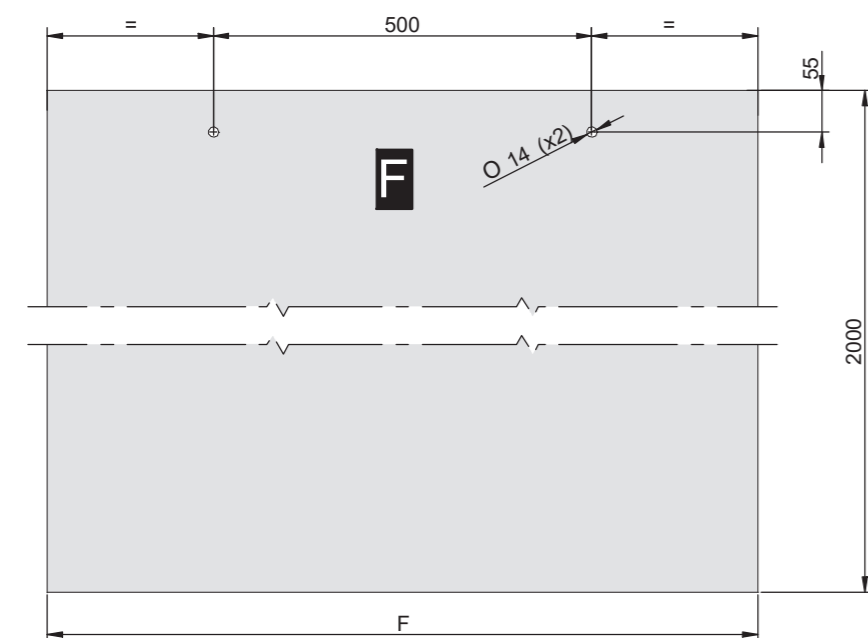

**VETRO FISSO**  
FIXED GLASS  
VERRE FIXE

**FORATURA DEI VETRI LATERALI**  
Side glass machining / Usinage de verr de côté

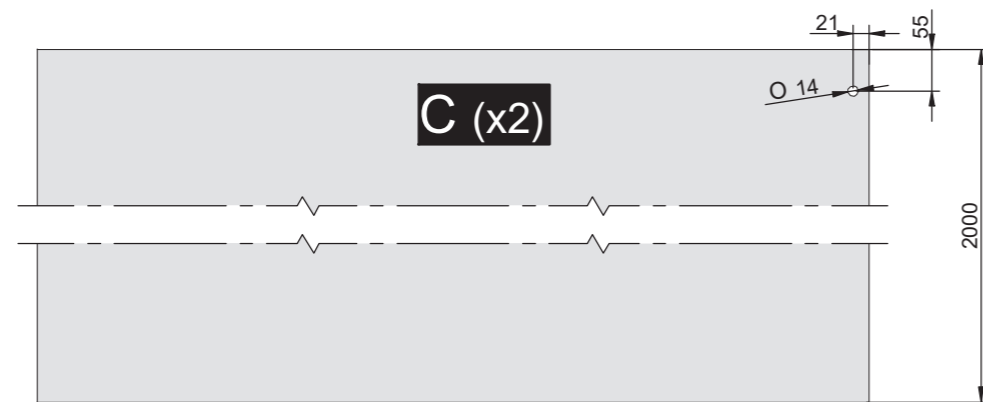

**GIBLI QUADRO**  
ANGOLO

Mc-Slide s.r.l.  
☎ mcslide.it  
✉ info@mcslide.it

Mc-Slide Spain -  
☎ mcslide.es  
✉ info@mcslide.es



FEB. 2014  
038

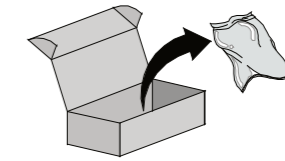

|   |  |   |
|---|--|---|
| f |  | 2 |
| g |  | 2 |
| j |  | 1 |
| k |  | 1 |

|   |  |   |
|---|--|---|
| a |  | 4 |
| b |  | 4 |
| c |  | 4 |
| d |  | 4 |
| e |  | 2 |
| i |  | 4 |

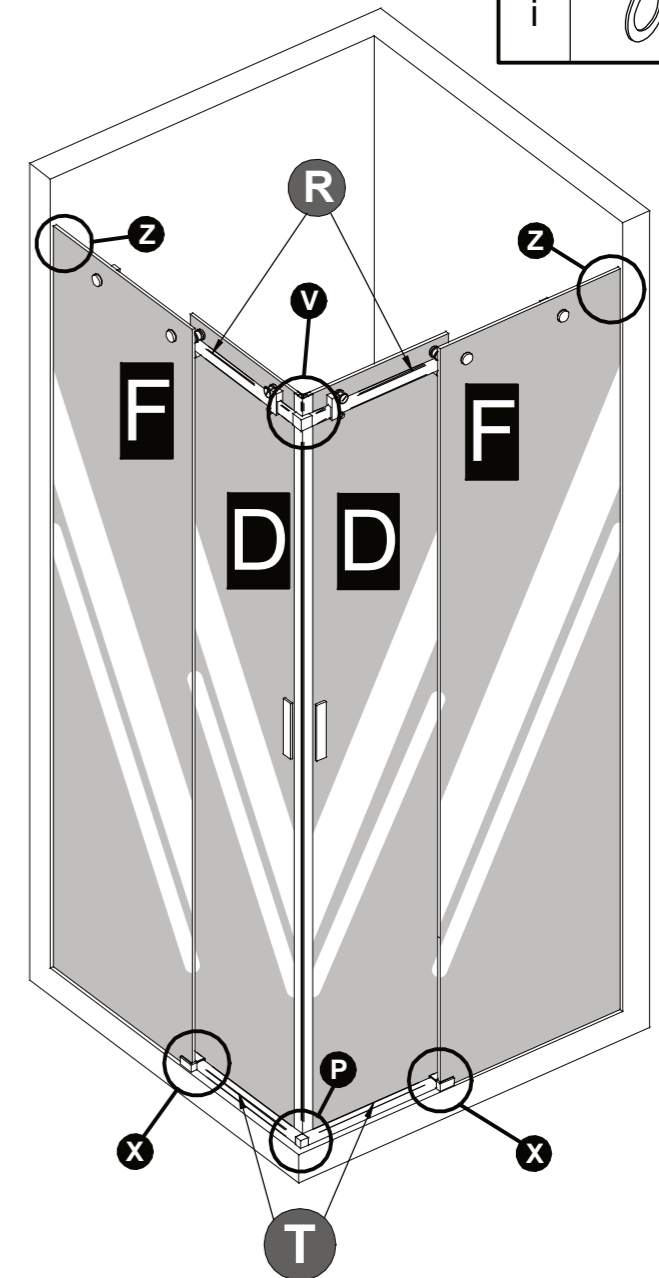
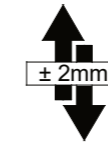
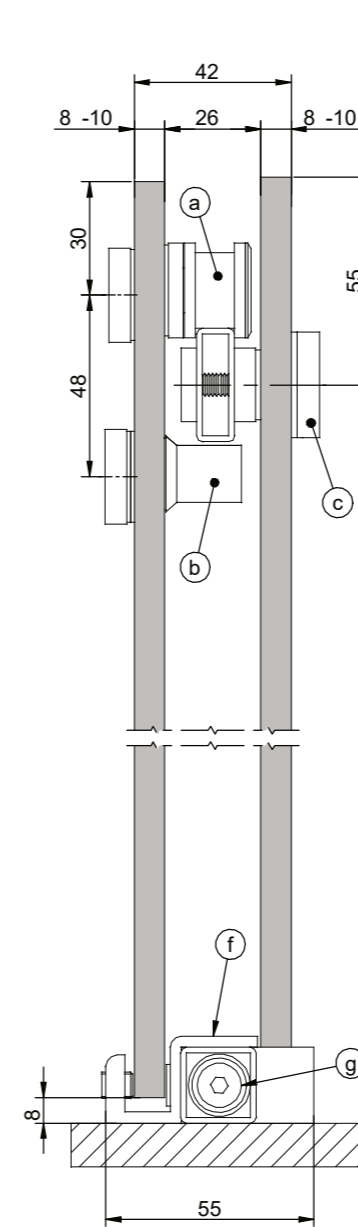

INSTALLAZIONE  
CON SORMONTO  
MANIGLIA

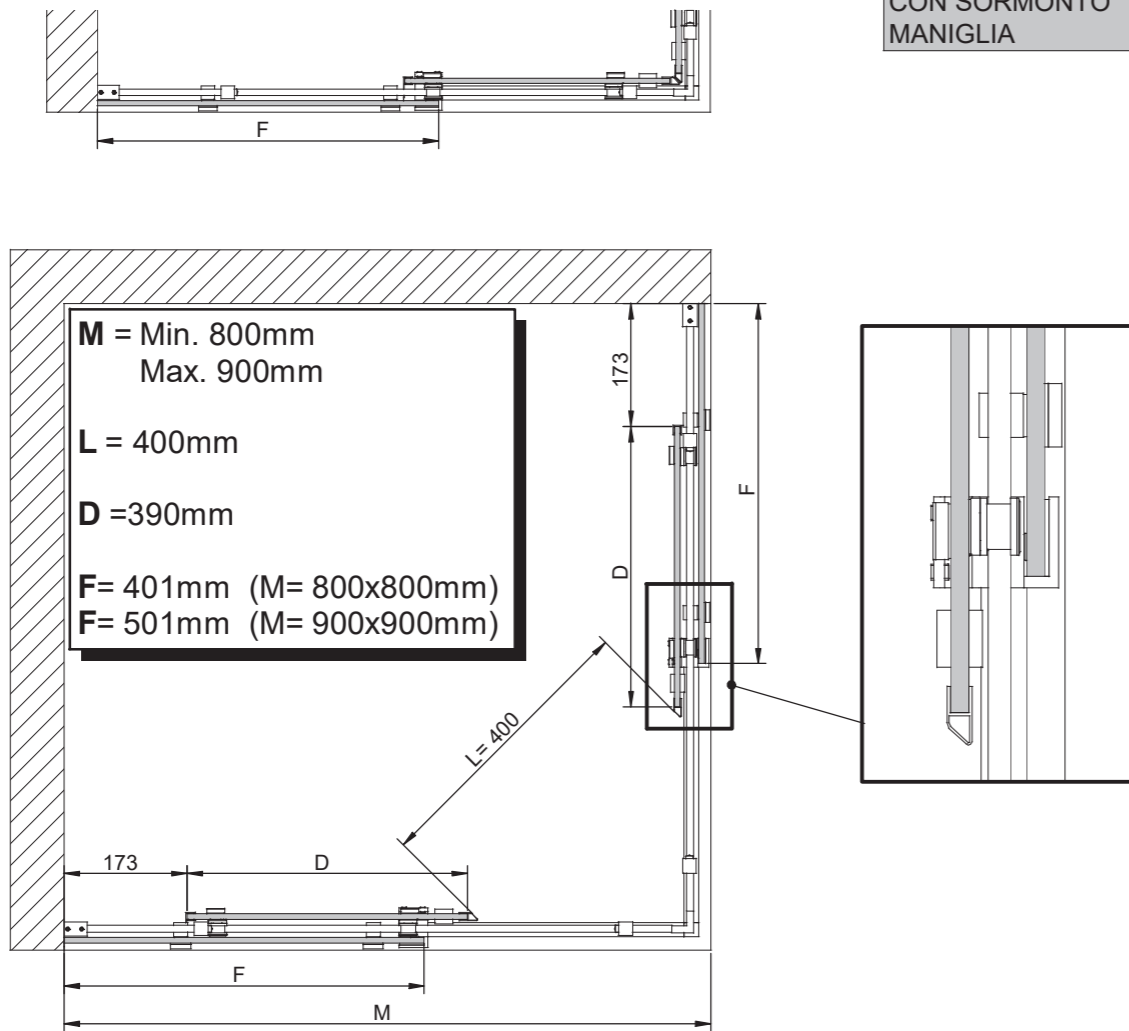

INSTALLAZIONE  
CON VETRI A RASO

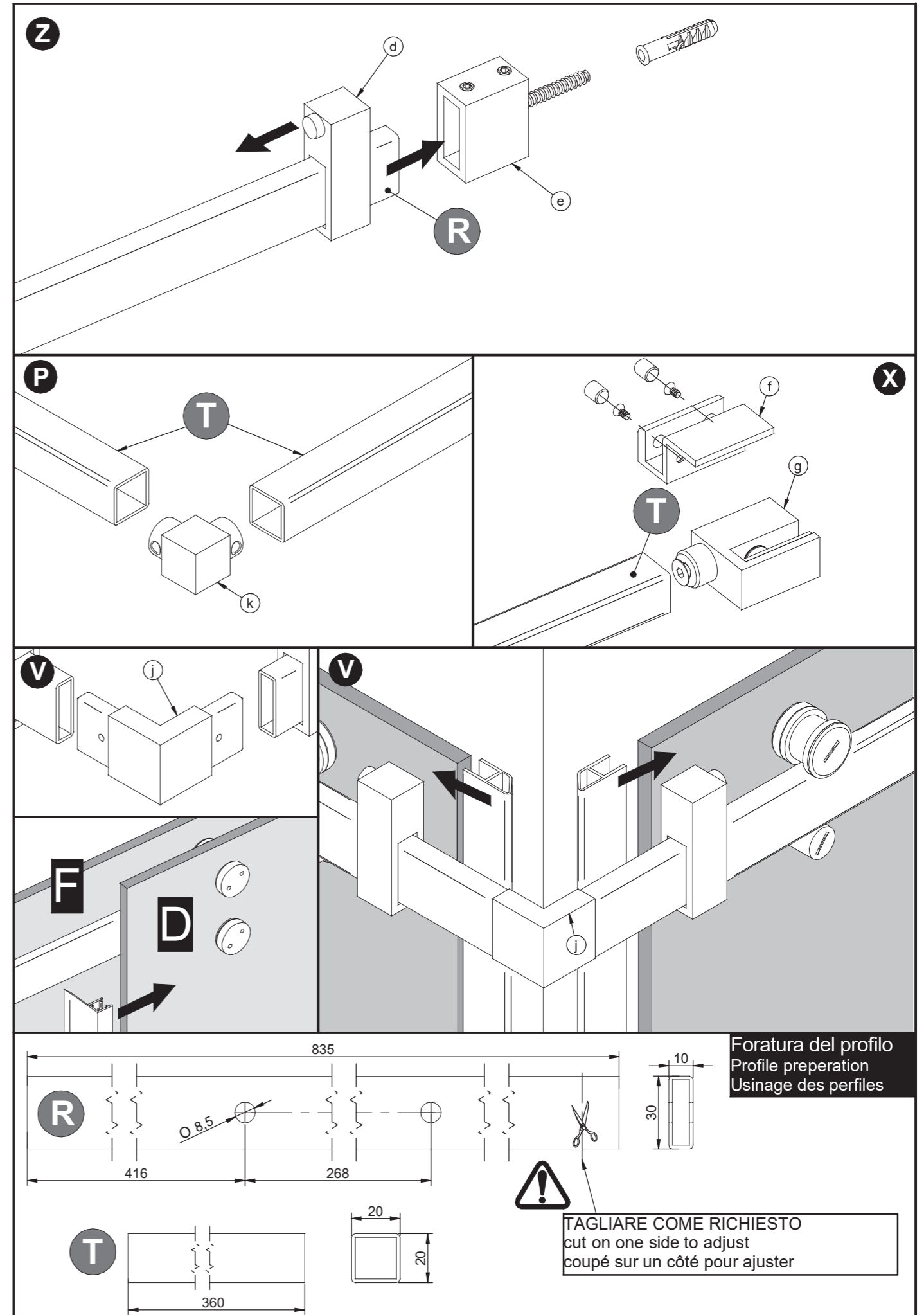
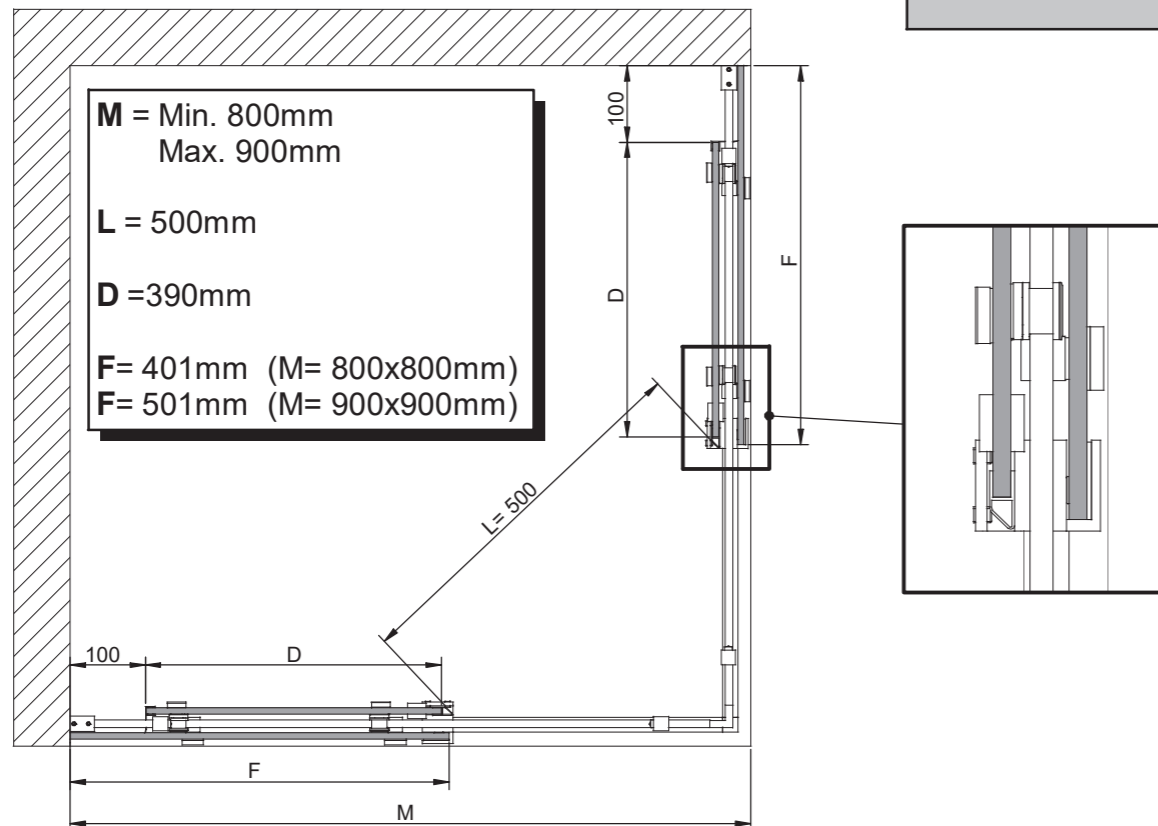

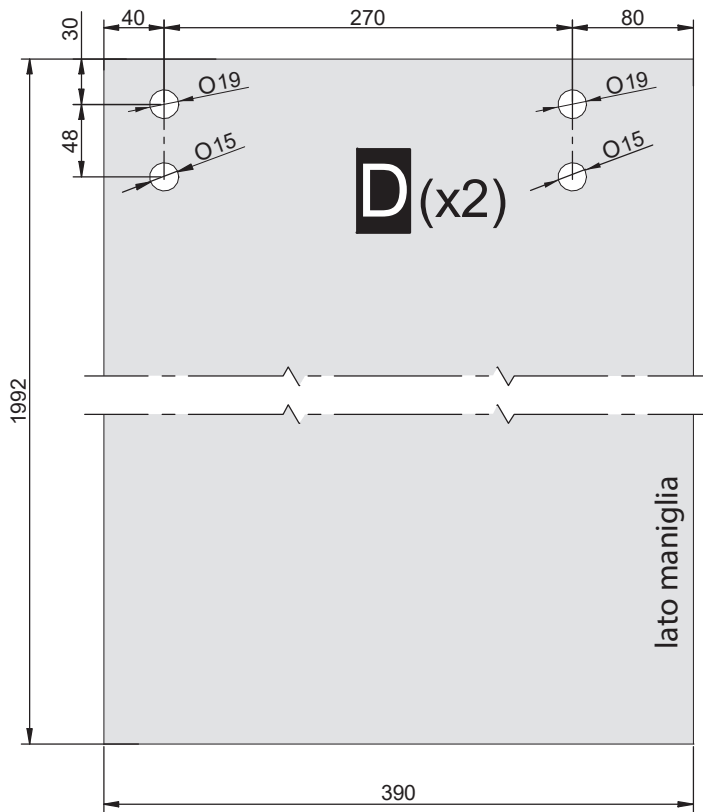

PORTE SCORREVOLI  
SLIDING DOOR  
PORTE COULISSANTE

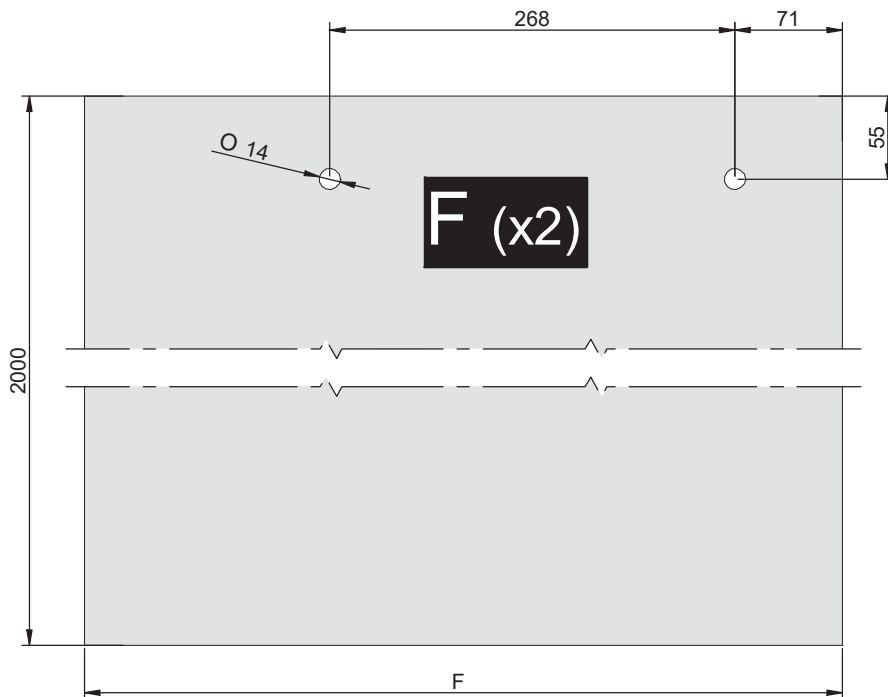

VETRI FISSI  
FIXED GLASS  
VERRE FIXE

Seguici sui Social Media  
Síguenos en redes



Mc-Slide s.r.l. - 🌐 [mcslide.it](http://mcslide.it) - ✉ [info@mcslide.it](mailto:info@mcslide.it)  
Mc-Slide Spain - 🌐 [mcslide.es](http://mcslide.es) - ✉ [info@mcslide.es](mailto:info@mcslide.es)